

# ControlDraw Demonstration

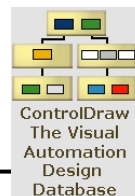
## A Model based on ISA 5.6

### Print and Review Report

Note - the model is under development but this indicates how to meet the requirements of the ISA 5.06 Standard

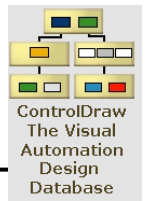
Functional Requirements Documentation for Control Software  
Applications  
Examples 1 and 2

This Reviewer report compares two versions of the model, the first was a preliminary issue, the second after much more development



## Table of Contents

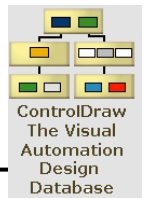
Section	Page
Cover	1
Table of Contents	2
Project Information	4
Diagrams	5
1 - Overview	5
2 - Guide and Key to symbols	7
3 - R10X	8
4 - CR101	10
5 - EM01	11
6 - RP	13
6. . . Variant 1 - Type 1	13
6. . . Variant 2 - Type 2	14
6. . . Variant 3 - Type 3	15
7 - up Recipe 1	16
8 - ph R10x Initial	18
9 - ph R10x Fill	20
9. . . Variant 1 - A	20
9. . . Variant 2 - B	21
9. . . Variant 3 - C	22
10 - ph R10x Heat	24
11 - ph R10x Cure	26
12 - ph R10x Dump	27
13 - UC102	28
14 - UC003	30
15 - UC104	31
16 - C104	32
17 - RP C	34
18 - Continuous Unit Procedure	35
19 - ph Run Evap	36
20 - ph Fill Evap	37
21 - UC111	38
22 - UC110	39
23 - UC102 (Column)	40
24 - UC104 (Column)	41
25 - On Off Valve	42
25. . . Variant 2 - Closed LS	42
25. . . variant 3 - 2 Limit Switches	43
26 - Fixed Speed Motor	46
27 - Variable Speed motor	48
28 - Standard PID Loop	50
29 - Control Valve	52
30 - Analog Input from Transmitter	54
31 - Flow Transmitter	56
32 - Alarm Switch Input	58
33 - Complete Graphic	60
34 - R10x Interlock matrix	62
35 - Database	64
36 - Interlock Matrix	65
37 - Sequence Matrix equivalences	66
Data Reports:	69
Control System IO - with changes	69
Interlock Control Module - with changes	71
Measurement Analog - with changes	72
Measurement Switch - with changes	73
Equipment Parameter - with changes	74
Recipe Formula Value - with changes	75



---

Deleted Pages	76
---------------	----

Control Draw 2008



**Project Information**

Item	Value
Project Name:	ISA-5.06.01-2007 Demo
Client:	ControlDraw Customers
Reviewer View Name:	ISA56 Demo Model with Changes in e:\E\_CDReference\Samples3\Comments3.mdb
Last edited with ControlDraw Version:	1141
Printed with Reviewer Version:	481

**View Contents**

- Information Page
- Diagram Descriptions
- 37 Diagrams
- 6 Data Reports
- Deleted Diagram List

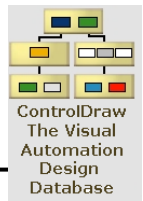
**Issue History**

Date	Issue	Version	Author	Details
06/09/2008	Major Issue - 1A	94	Francis Lovering	Publish for ControlDraw customers and Web Demonstration
03/09/2008	Minor Issue - 0B	56	Francis Lovering	Third preliminary issue for web
31/08/2008	Minor Issue - 0A	35	Francis Lovering	First preliminary issue

Change highlight colours

Changed data  New data  Null(empty) data   
 Previous version BackGround  Deleted object  New object   
 Changed text  Moved object 

Control Draw 2008



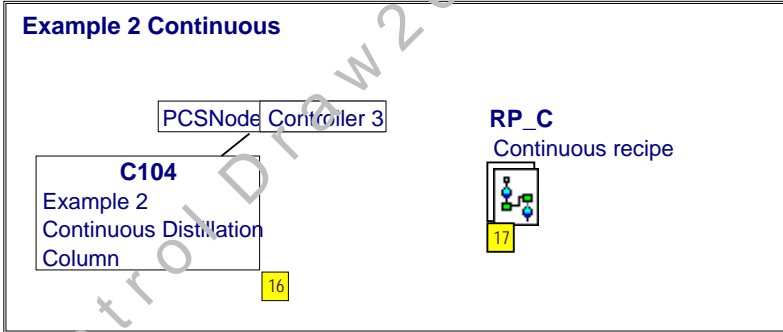
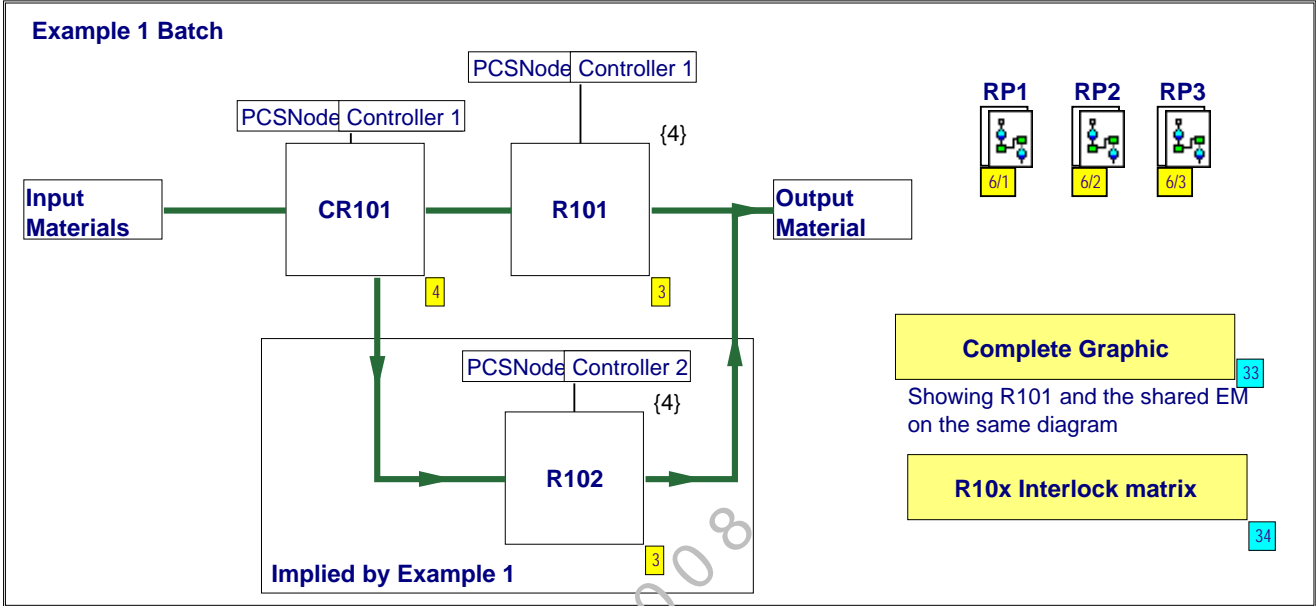
**Diagram 1 - Overview**

Diagram Version: 93

Class: Process Cell

**Based on**  
 AMERICAN NATIONAL STANDARD ANSI/ISA-5.06.01-2007  
 Functional Requirements Documentation for Control Software Applications  
 Examples 1 and 2

**Guide and Key to symbols**

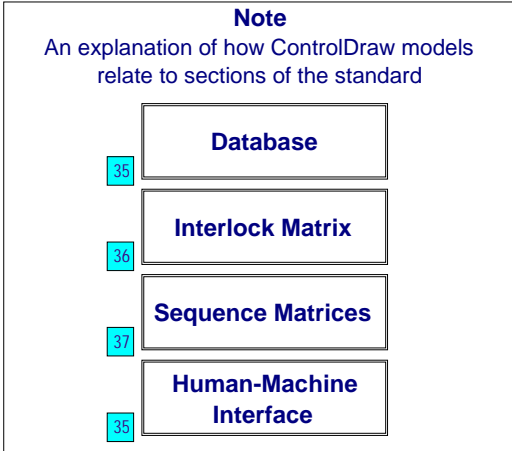


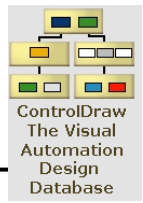
**Examples from database**  
Automatically generated

IO Type	Count
AI	14
AO	12
DI	20
DO	15
<b>Total</b>	<b>61</b>

IO Count database query

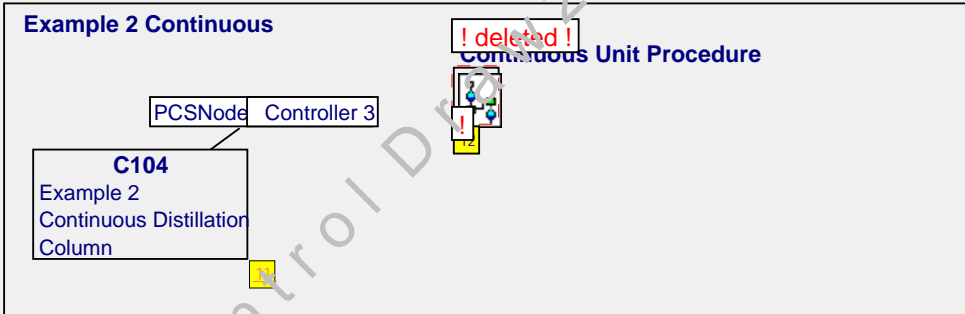
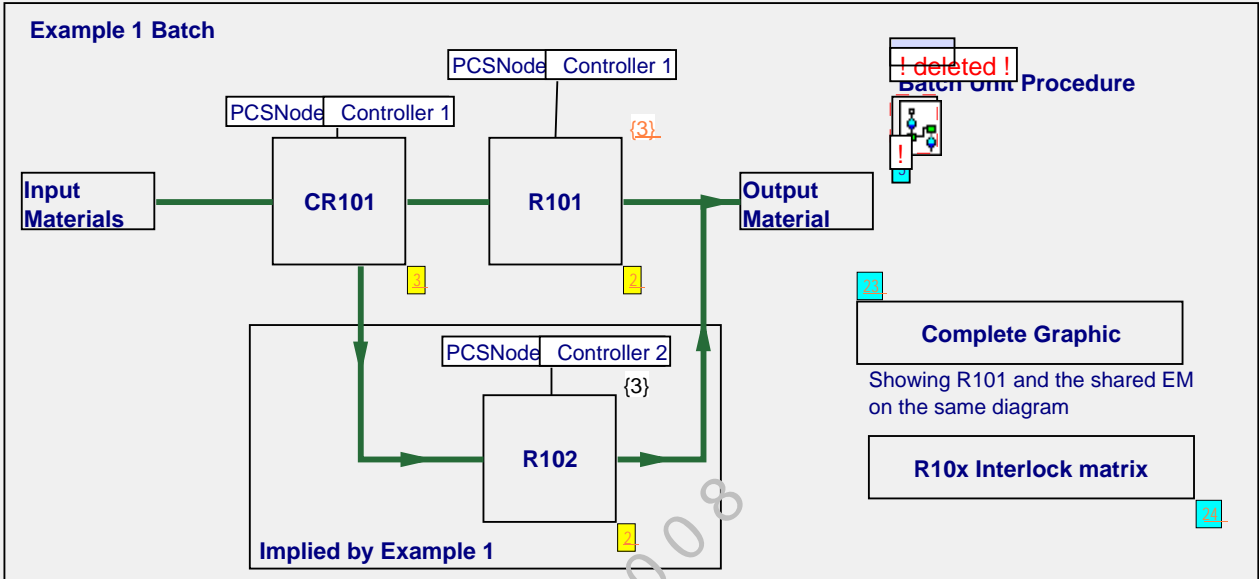
IO Count by Controller (PCS)			
IO Type	Controller 1	Controller 2	Controller 3
AI	3	2	9
AO	3	2	7
DI	12	4	4
DO	9	3	3
<b>Total</b>	<b>27</b>	<b>11</b>	<b>23</b>





Previous diagram for Page 1, PageID 4  
 Previous version, page 1, Version 55  
 From model E:\FcdArchive\ISA506Demo\_56.cnd

**Based on**  
 AMERICAN NATIONAL STANDARD ANSI/ISA-5.06.01-2007  
 Functional Requirements Documentation for Control Software Applications  
 Examples 1 and 2



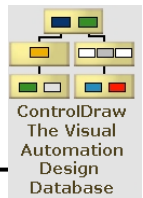
IO Type	Count	IO Count database query
AI	14	
AO	12	
DI	18	
DO	15	
Total	59	

**IO Count by Controller query**

IO Type	<>	Controller 1	Controller 2	
AI	5	3	2	
AO	3	3	2	
DI	2	11	3	2
DO	1	9	3	2
Total	11	26	10	12

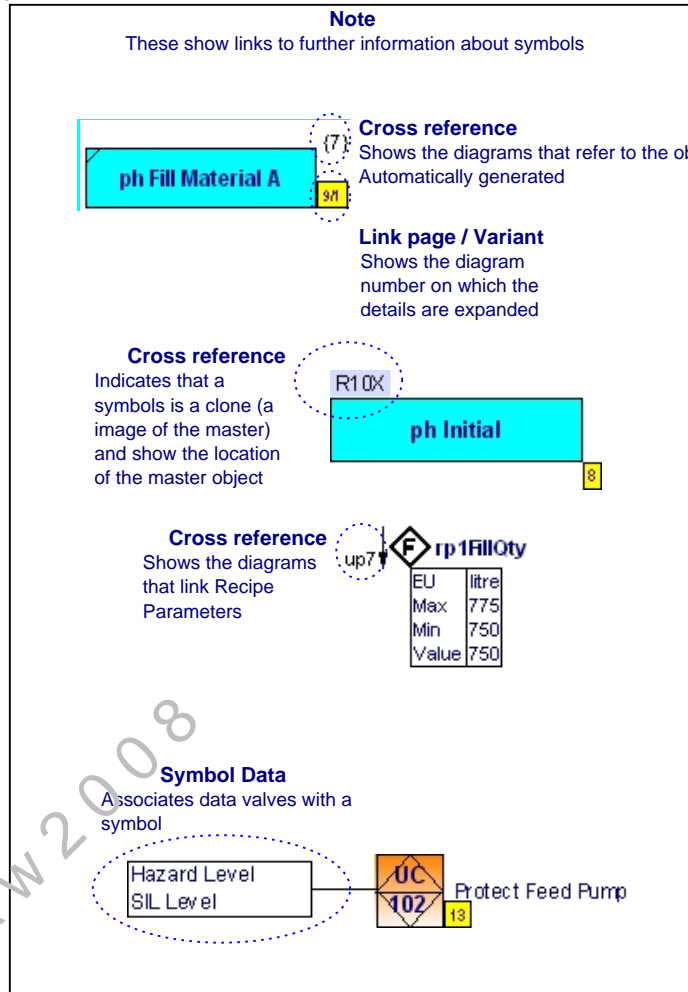
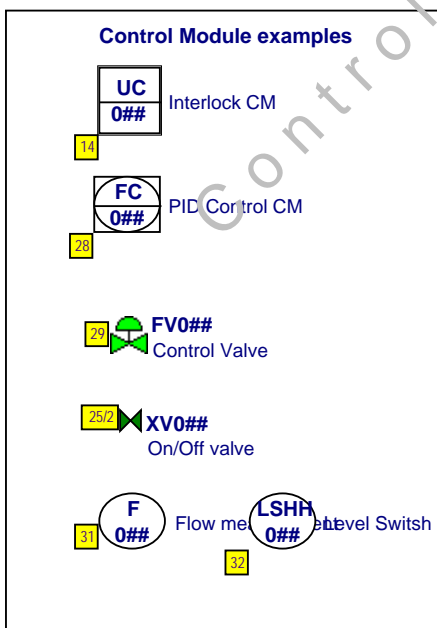
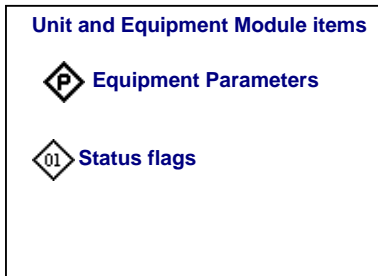
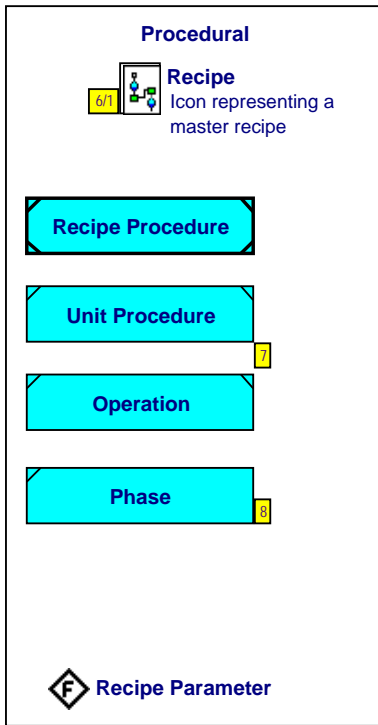
**Note**  
 An explanation of how ControlDraw models relate to sections of the standard

- Database
- Interlock Matrix
- Sequence Matrix
- Human-Machine Interface



**Diagram 2 - Guide and Key to symbols**

Diagram Version: 90 Class: Document Reference



Example of an equipment phase, steps and transition refer to objects in the model

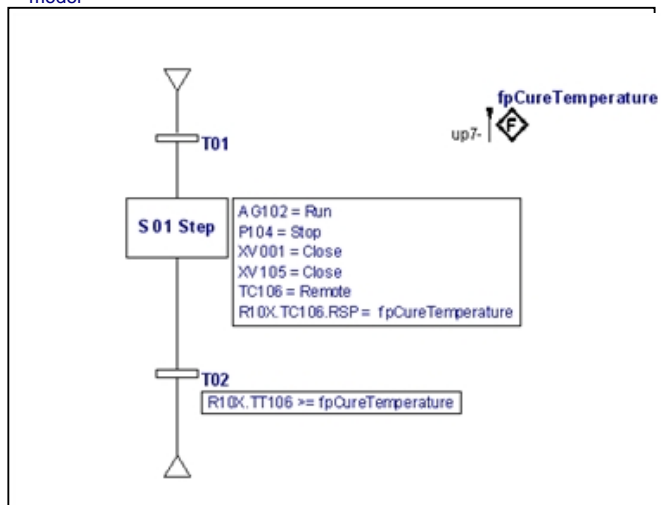
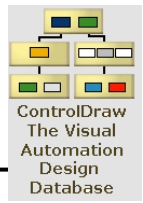
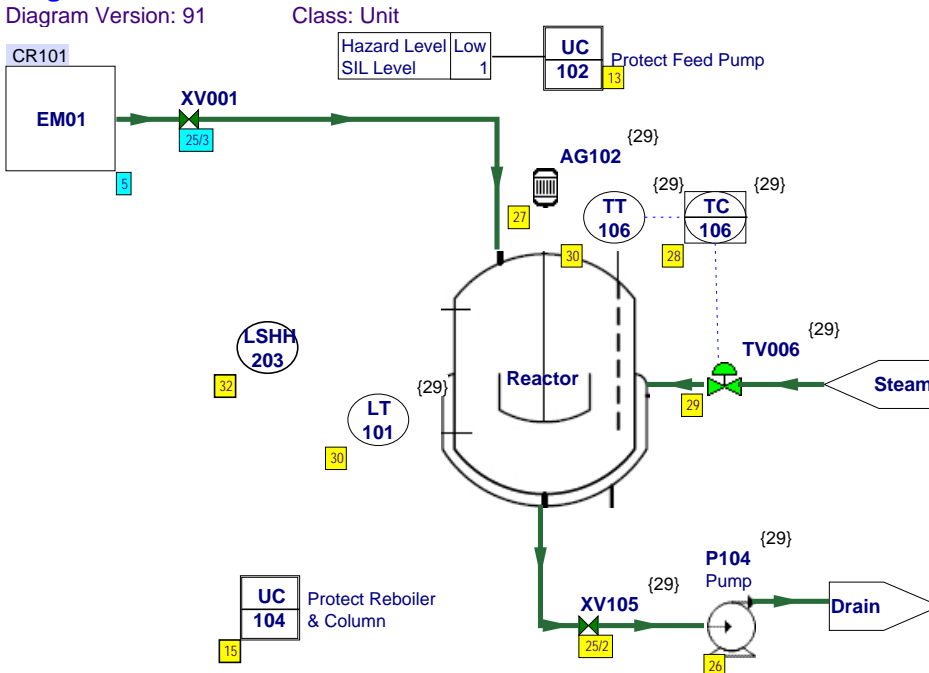


Diagram did not exist in previous version of the model



**Diagram 3 - R10X**

Diagram Version: 91



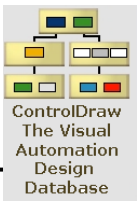
Phases	
ph Initial	{7}
ph Fill Material A	{7}
ph Fill Material B	{7}
ph Fill Material C	{7}
phHeat	{7}
ph Cure	{7}
ph Dump	{7}
ph Shutdown	{7}

**Note**  
Product goes down the drain!

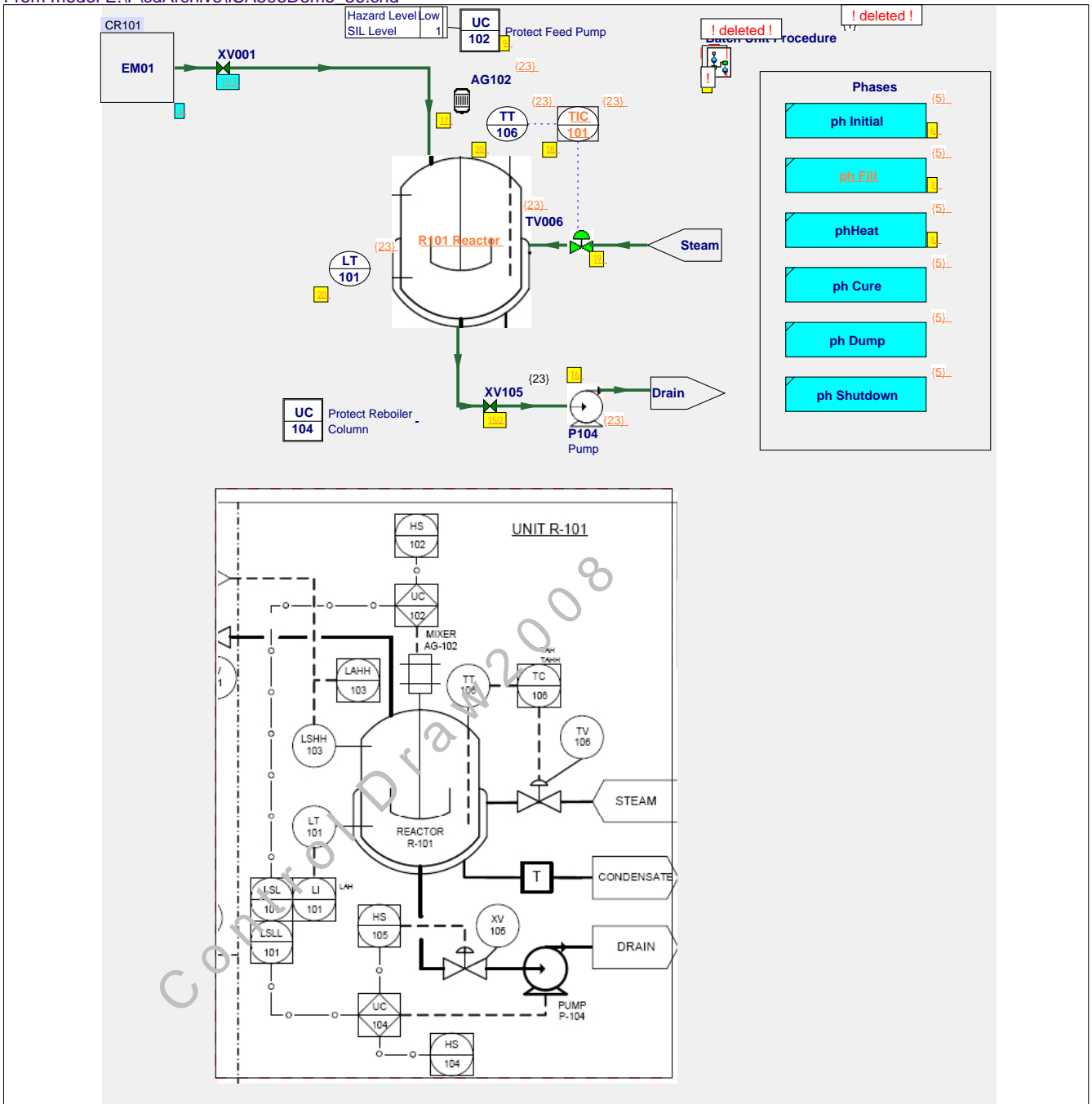
Equipment Parameters	
Non Recipe Parameters Like 'variables coded in program' in the example, but that is not a good idea	
<b>P</b>	epMinAgitateLevel
<b>P</b>	epEmptyLevel
<b>P</b>	epDrainTime
<b>P</b>	epMinPumpLevel

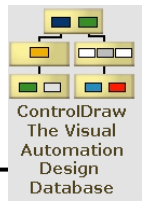
Status flags	
<b>bln</b>	AllInAuto {01}
<b>bln</b>	NoAlarms {01}
<b>bln</b>	DevicesAllSet {01}

Control Draw 2008



Previous diagram for Page 3, PageID 3  
Previous version, page 2, Version 55  
From model E:\FcdArchive\ISA506Demo\_56.cnd



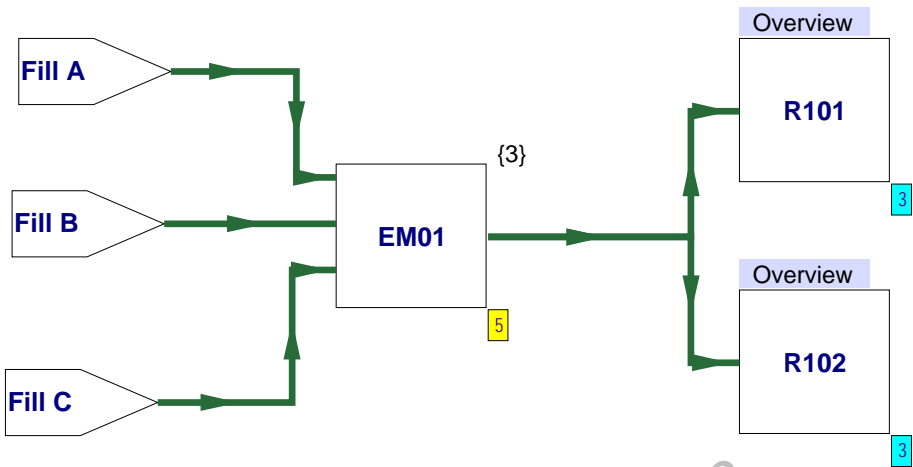


**Diagram 4 - CR101**

Diagram Version: 49      Class: Common Resource

**This is a common Resource**

It contains the shared equipment module the supplies either reactor.  
This level in the Hierarachy is not stated as present in the S88.91 models,  
but having it improves the consistency of the model.



Previous version is same as current, 49

Control Draw 2008

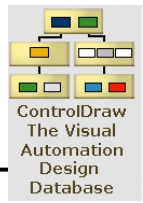
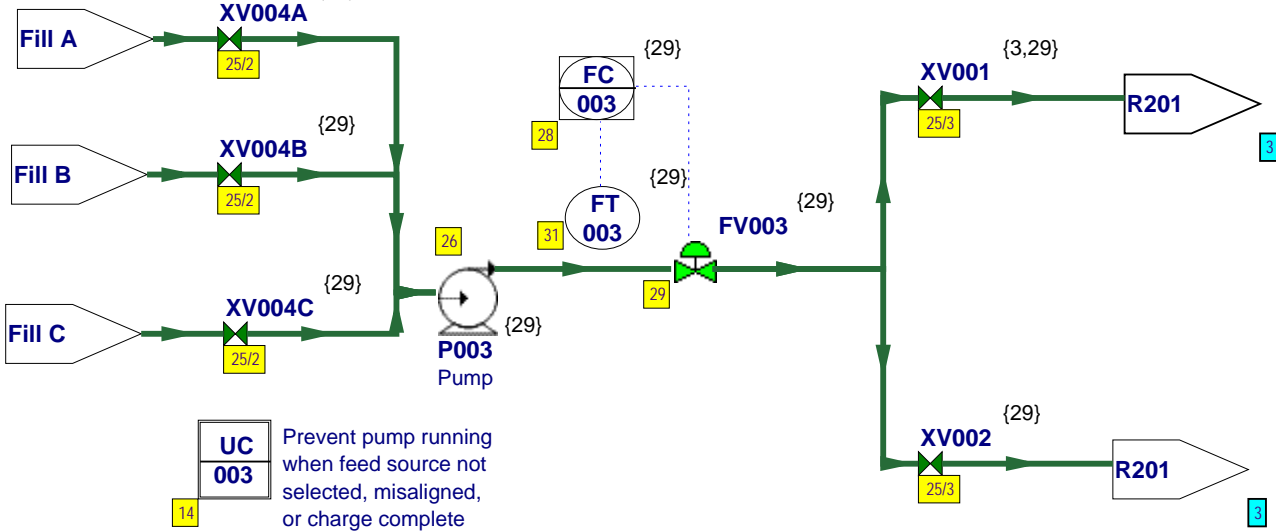


Diagram 5 - EM01

Diagram Version: 91

Class: Equipment Module  
{29}

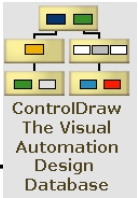


Note - not all these have yet been incorporated in this model

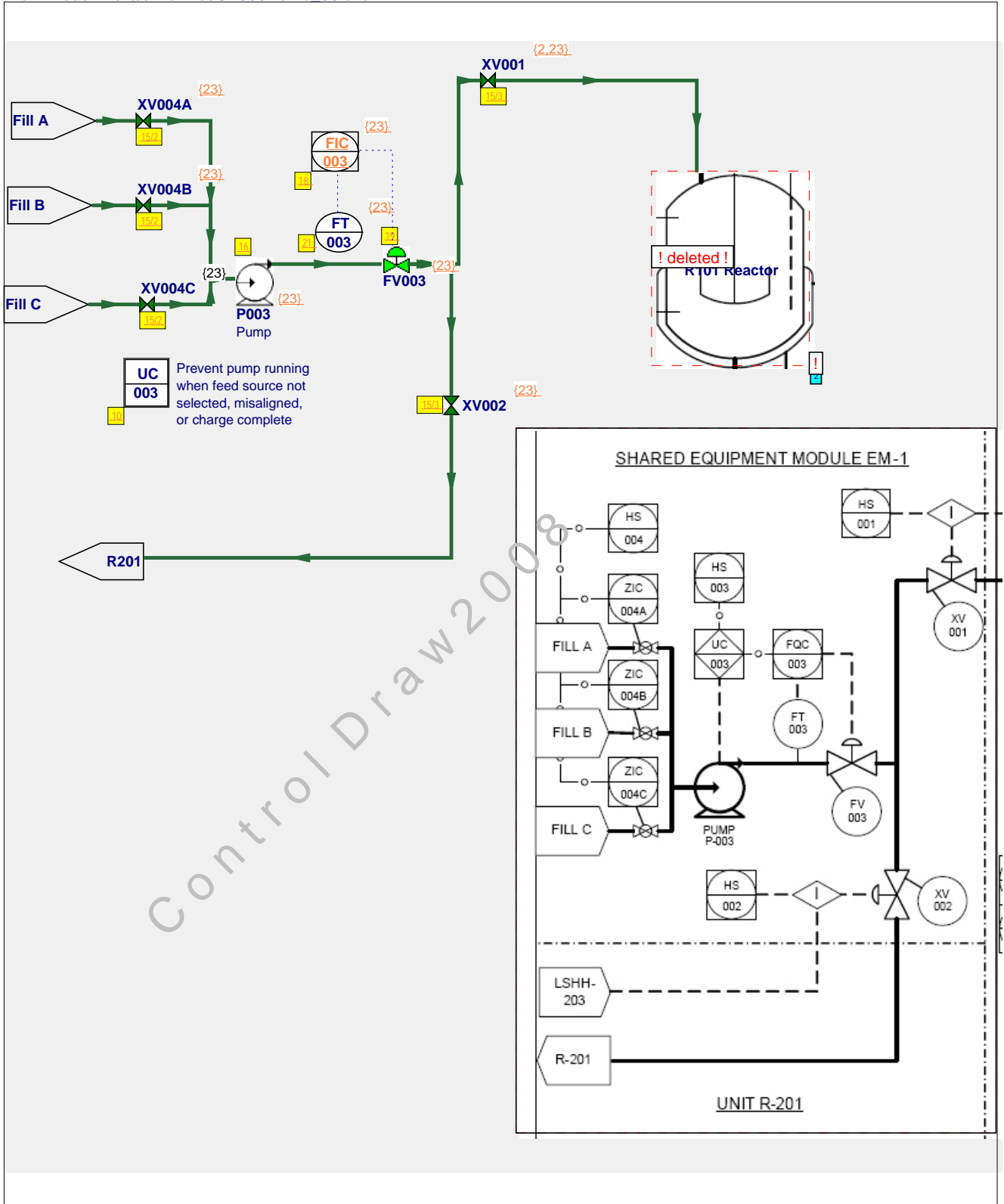
ID NUMBER	INITIATING DEVICES (FAULT)	CONTROL DEVICES (ACTION)	OPERATING MODE	INTERLOCK PURPOSE
	SETPOINTS	LOGIC		
*	{LAHH-103 IN ALARM (ALSO HARDWIRED****)} OR {R01.BATCHID ↔ EM1.BATCHID **} OR {XV-002 OPEN (ZSC-002 OFF)} OR {HS-004 MISALIGNED (INPUT STATE)}	CLOSE XV-001 (HS-001 OFF)	MANUAL RESET	PREVENT R-101 FROM OVERFLOWING, CONFIRM PROCESS OWNER, INTEGRITY OF CHARGE MEASUREMENT, AND PREVENT CHARGING WRONG MATERIAL
*	{LAHH-203**** IN ALARM (ALSO HARDWIRED****)} OR {R02.BATCHID ↔ EM1.BATCHID **} OR {XV-002 OPEN (ZSC-002 OFF)} OR {HS-004 MISALIGNED (INPUT STATE)}	CLOSE XV-002 (HS-002 OFF)	MANUAL RESET	PREVENT REACTOR FROM OVERFLOWING, CONFIRM PROCESS OWNER, INTEGRITY OF CHARGE MEASUREMENT, AND PREVENT CHARGING WRONG MATERIAL
*	{XV-001 FB_ERR OR XV-002 FB_ERR (ALARM STATES)} OR {XV-001 CLOSED AND XV-002 CLOSED (COMMAND STATES)} OR {HS-004 CLOSED (INPUT STATE)}	STOP P-003 (HS-003 OFF)	MANUAL RESET	INTEGRITY OF CHARGE PATH, PREVENT PUMP RUNNING WITH DISCHARGE BLOCKED, AND PREVENT PUMP RUNNING WITH INLET BLOCKED
*	P-003 RUNNING (XI-003 ON)	START FQC-003 INTEGRATION (FQ-003 ACCUMULATOR)	MANUAL RESET	INTEGRITY OF CHARGE MEASUREMENT

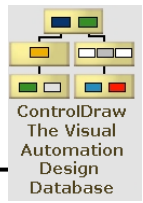
\* Not shown on P&ID  
 \*\* BATCHID's allocated by recipe after confirming EM or unit availability  
 \*\*\* SIL satisfied by hardwired protection; independent software layer provided for proper HS operation.  
 \*\*\*\* LAHH-203 specified separately in R-201 database matrix

Figure 11b — Software interlock matrix for Equipment Module EM-1



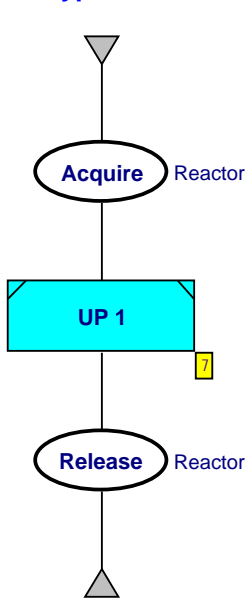
Previous diagram for Page 5, PageID 2  
Previous version, page 4, Version 49  
From model E:\FcdArchive\ISA506Demo\_56.cnd





**Diagram 6 - RP**  
 Diagram Version: 90  
 Variant 1 - Type 1

Class: Recipe Procedure



up7 ↓ **F** rp1FillQty

EU	litre
Max	775
Min	750
Value	750

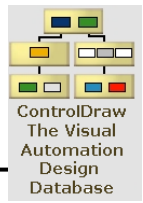
up7 ↓ **F** rp1CureTemperature

EU	DegC
Max	
Min	
Value	50

up7 ↓ **F** rp1CureTime

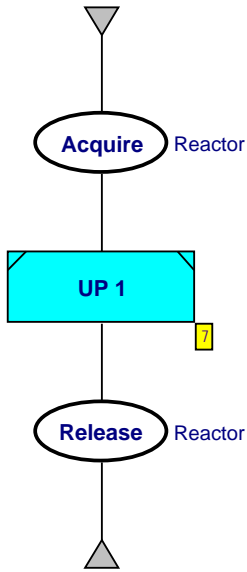
EU	Minutes
Max	200
Min	150
Value	150

Control Draw 2008



**Diagram 6 - RP**  
 Diagram Version: 90  
**Variant 2 - Type 2**

Class: Recipe Procedure



up7 ↓ **F rp2FillQty**

EU	litre
Max	875
Min	850
Value	850

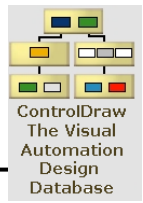
up7 ↓ **F rp2CureTemperature**

EU	DegC
Max	70
Min	50
Value	60

up7 ↓ **F rp2CureTime**

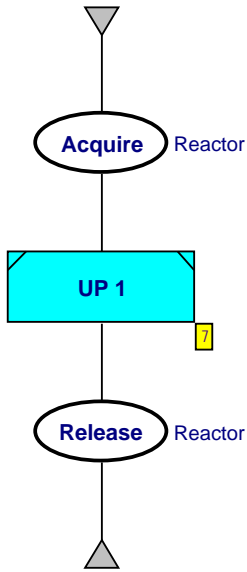
EU	Minutes
Max	229
Min	190
Value	199

Control Draw 2008



**Diagram 6 - RP**  
Diagram Version: 90  
**Variant 3 - Type 3**

Class: Recipe Procedure



up7 ↓ **F rp3FillQty**

EU	litre
Max	975
Min	950
Value	950

up7 ↓ **F rp3CureTemperature**

EU	DegC
Max	75
Min	55
Value	60

up7 ↓ **F rp3CureTime**

EU	Minutes
Max	1000
Min	990
Value	990

Control Draw 2008

Diagram did not exist in previous version of the model

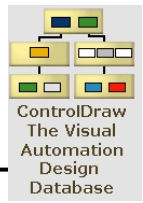
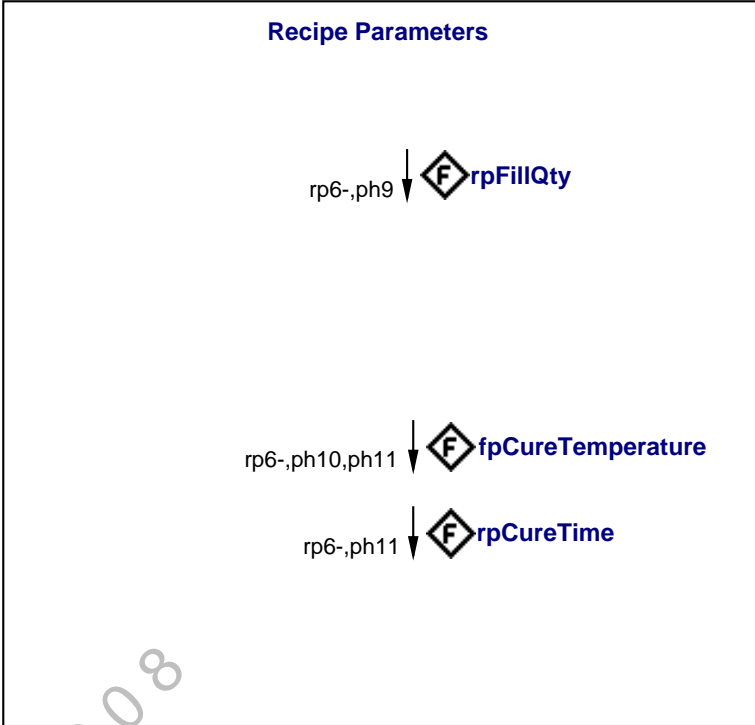
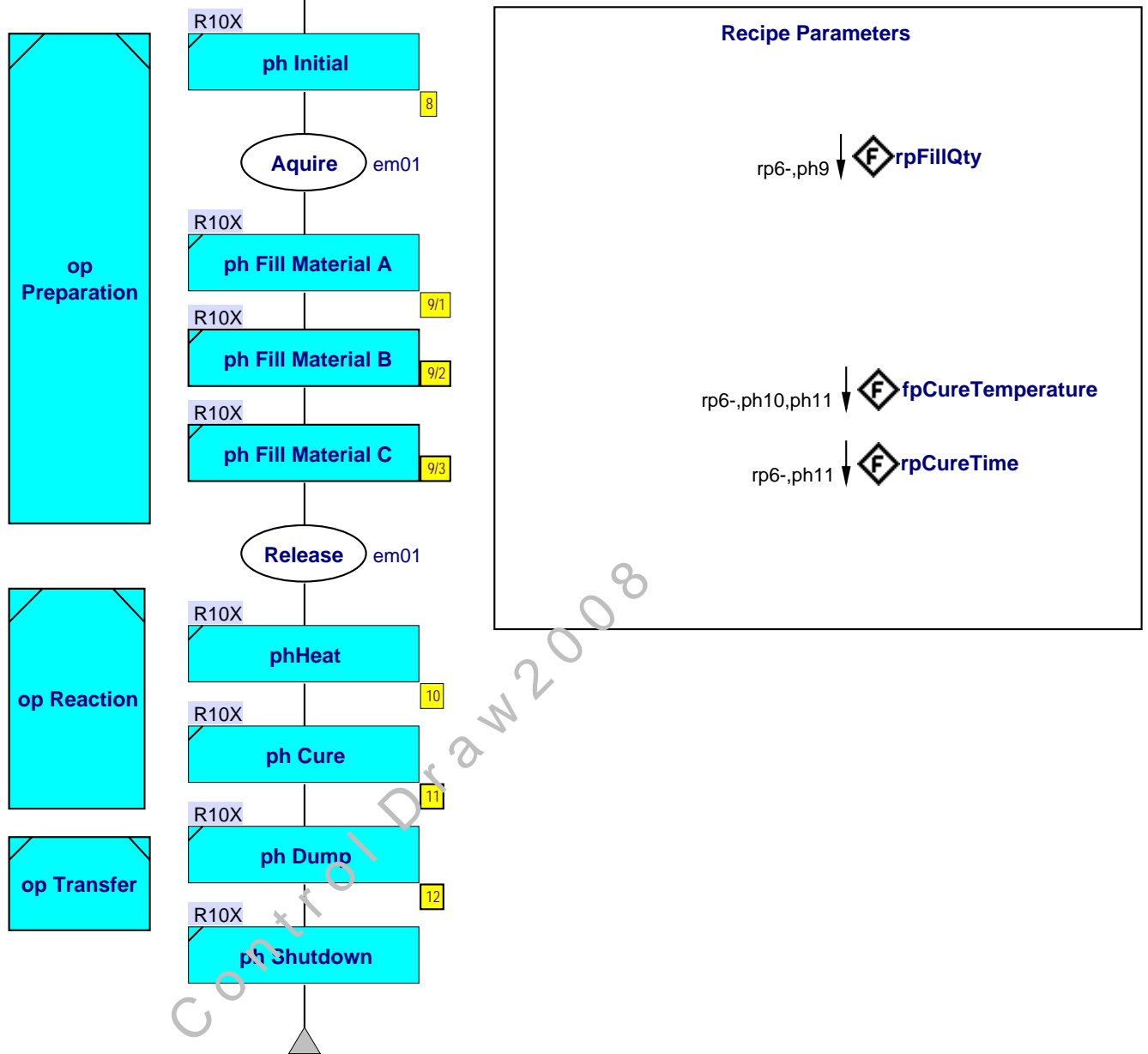
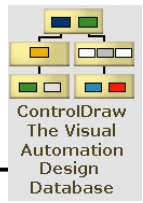


Diagram 7 - up Recipe 1

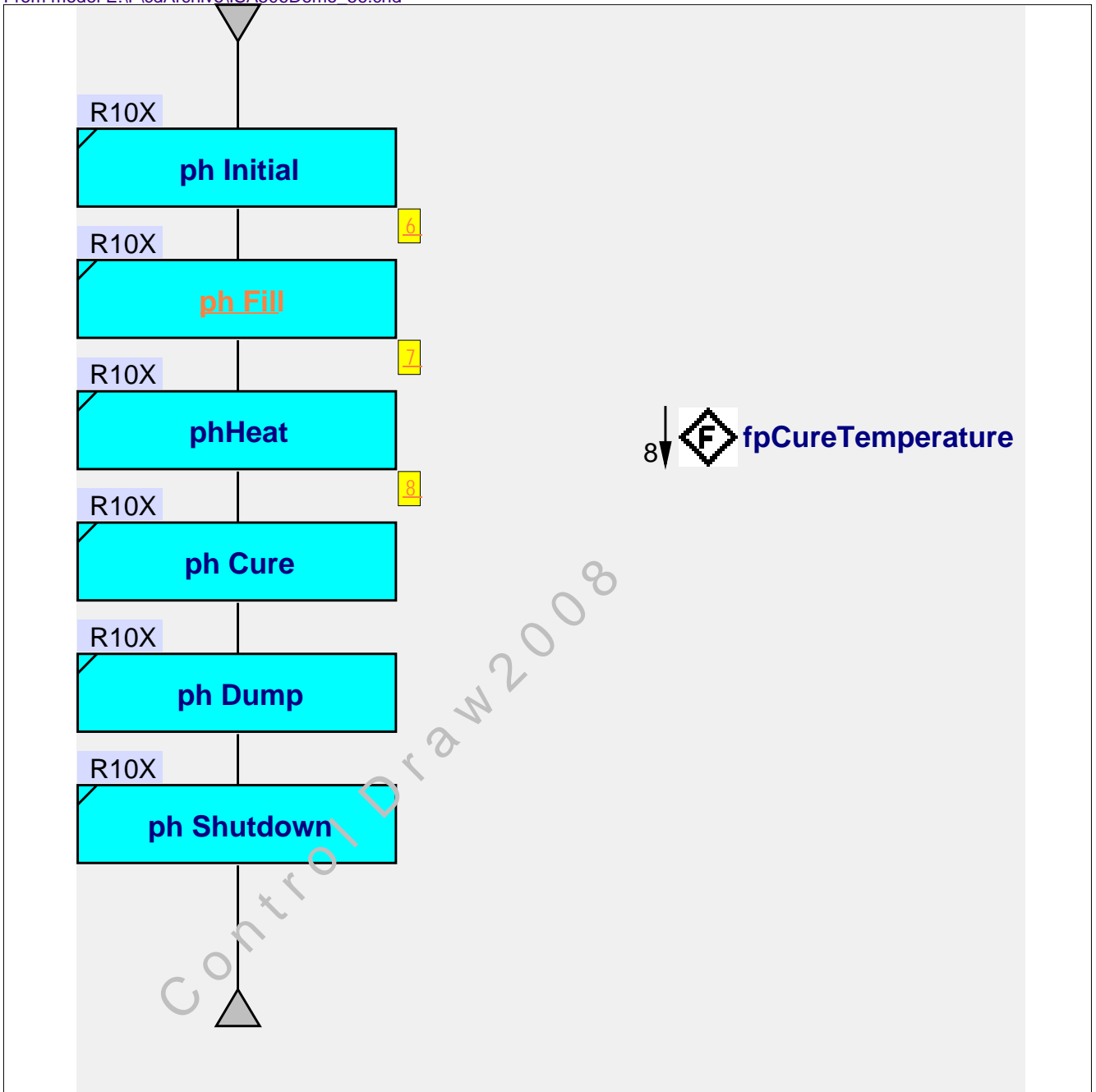
Diagram Version: 90

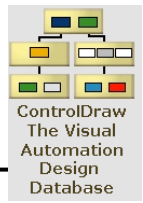
Class: Unit Procedure





Previous diagram for Page 7, PageID 30  
Previous version, page 5, Version 40  
From model E:\FcdArchive\ISA506Demo\_56.cnd



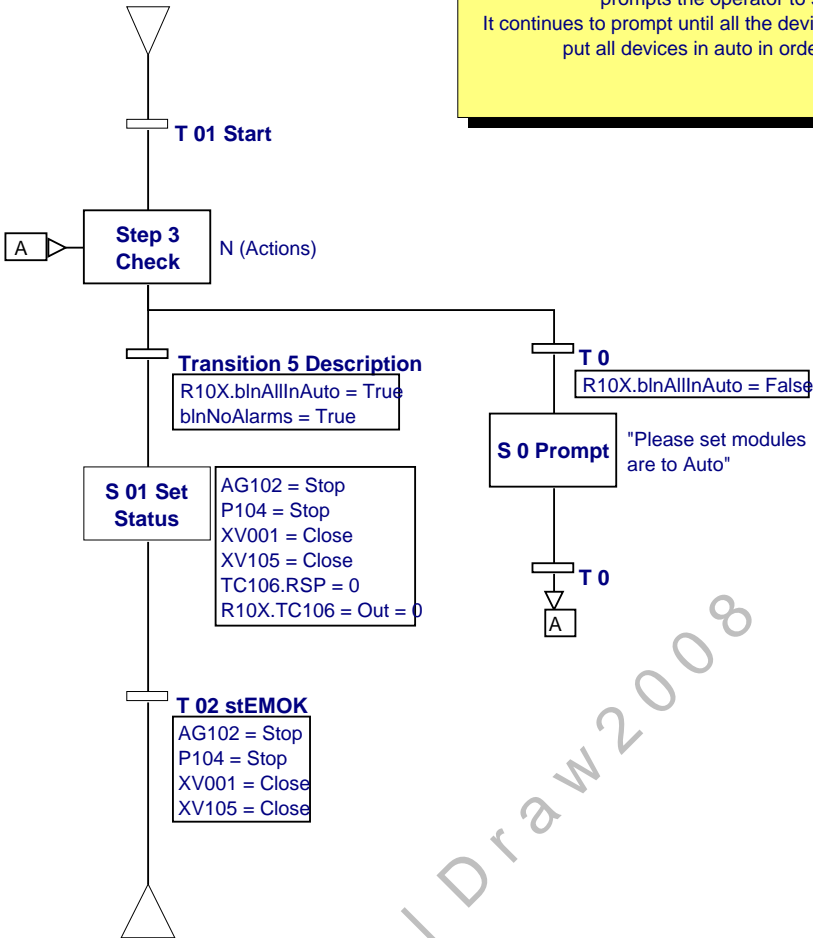


**Diagram 8 - ph R10x Initial**

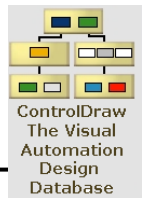
Diagram Version: 68      Class: Phase

**Note**

This phase checks that the unit is in auto (ie all it's modules are in Auto) and prompts the operator to set them if they are not. It continues to prompt until all the devices are in auto, so the operator **MUST** put all devices in auto in order to complete the operation.



Control Draw 2008



Previous diagram for Page 8, PageID 32  
Previous version, page 6, Version 34  
From model E:\FcdArchive\ISA506Demo\_56.cnd

**Note**  
This phase checks that the unit is in auto (ie all it's modules are in Auto) and prompts the operator to set them if they are not. It continues to prompt until all the devices are in auto, so the operator **MUST** put all devices in auto in order to complete the operation.



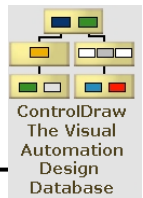
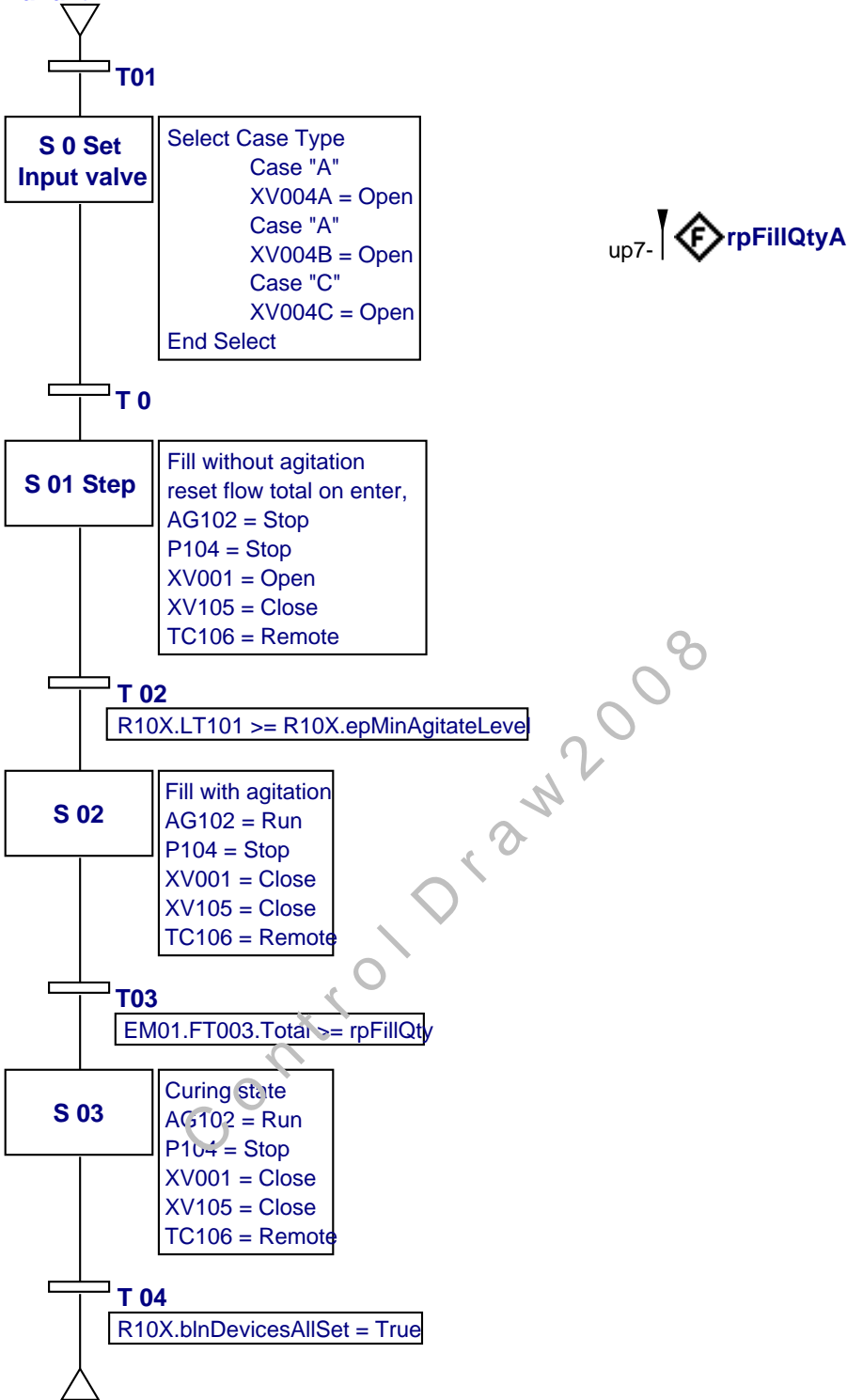


Diagram 9 - ph R10x Fill

Diagram Version: 82      Class: Phase

Variant 1 - A



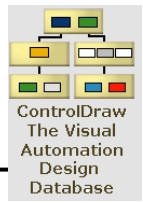
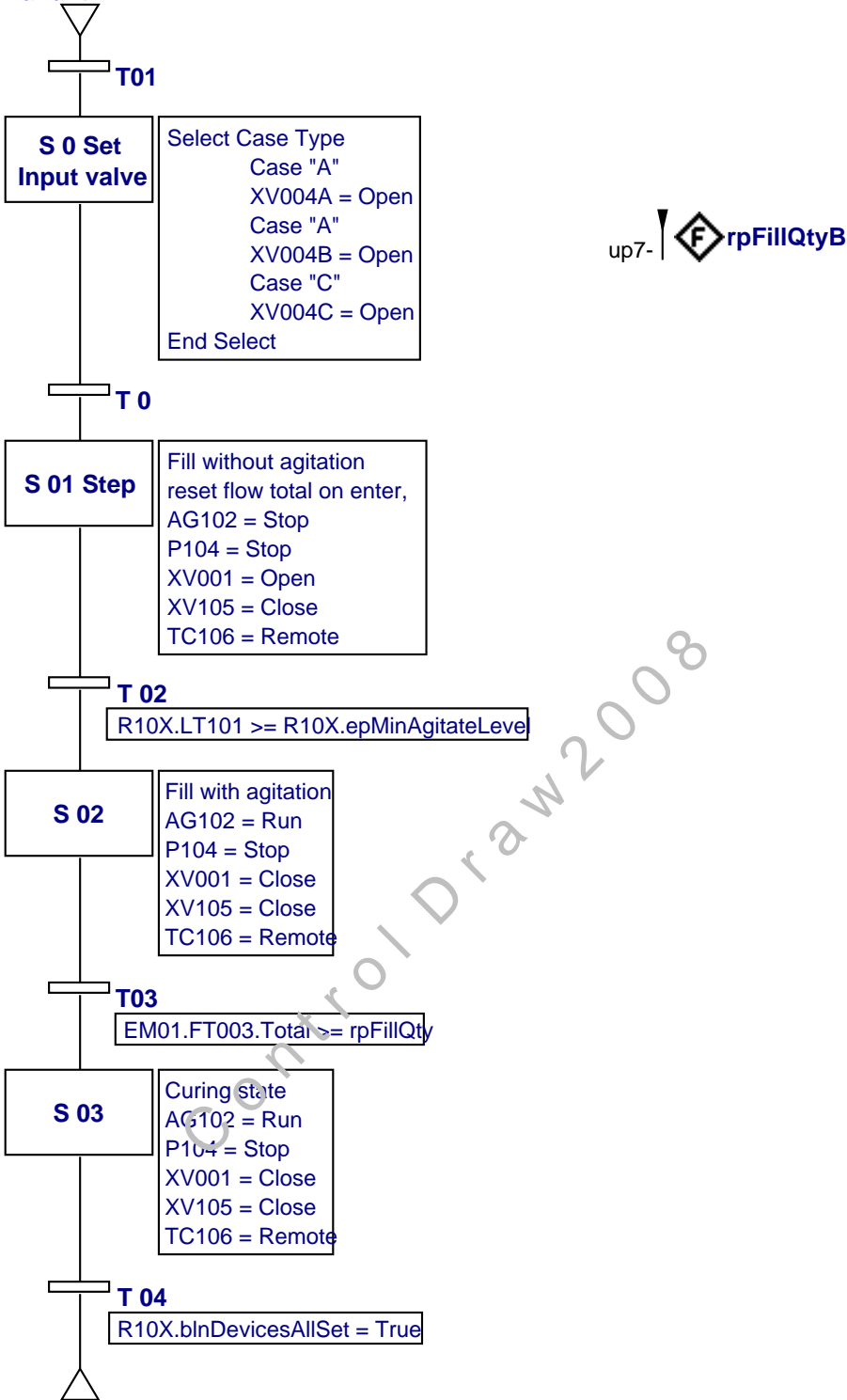


Diagram 9 - ph R10x Fill

Diagram Version: 82      Class: Phase

Variant 2 - B



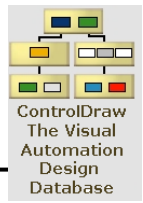
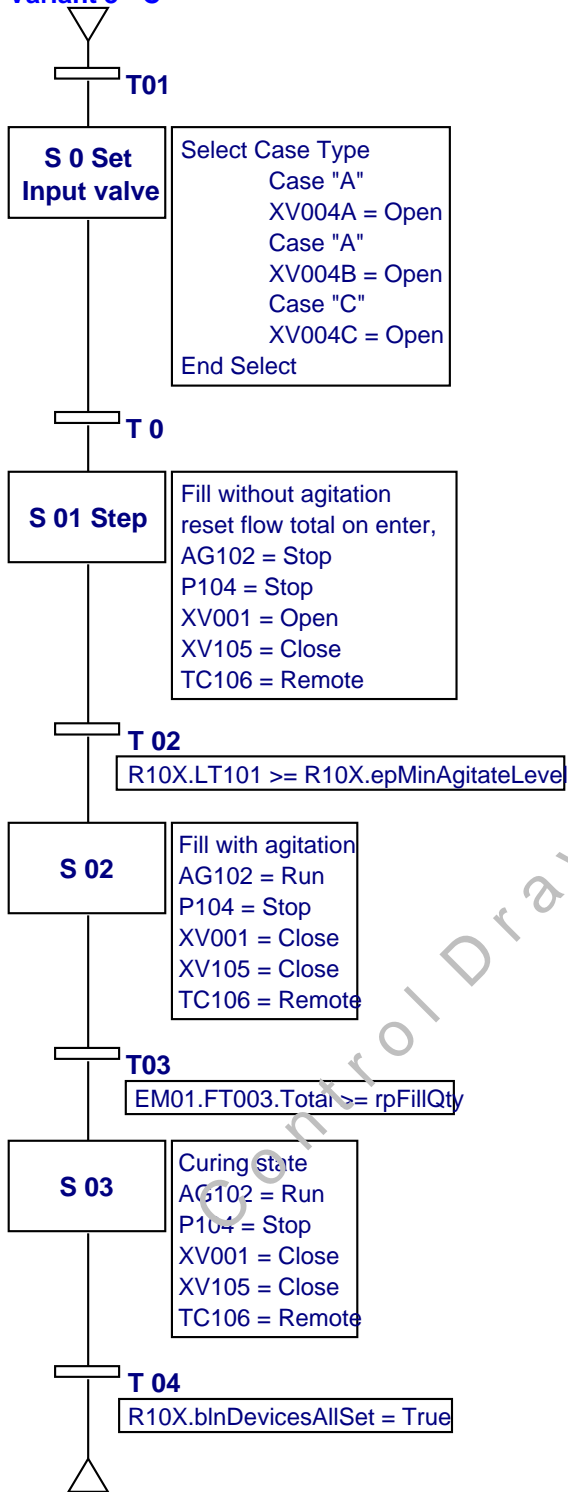


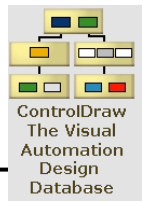
Diagram 9 - ph R10x Fill

Diagram Version: 82 Class: Phase

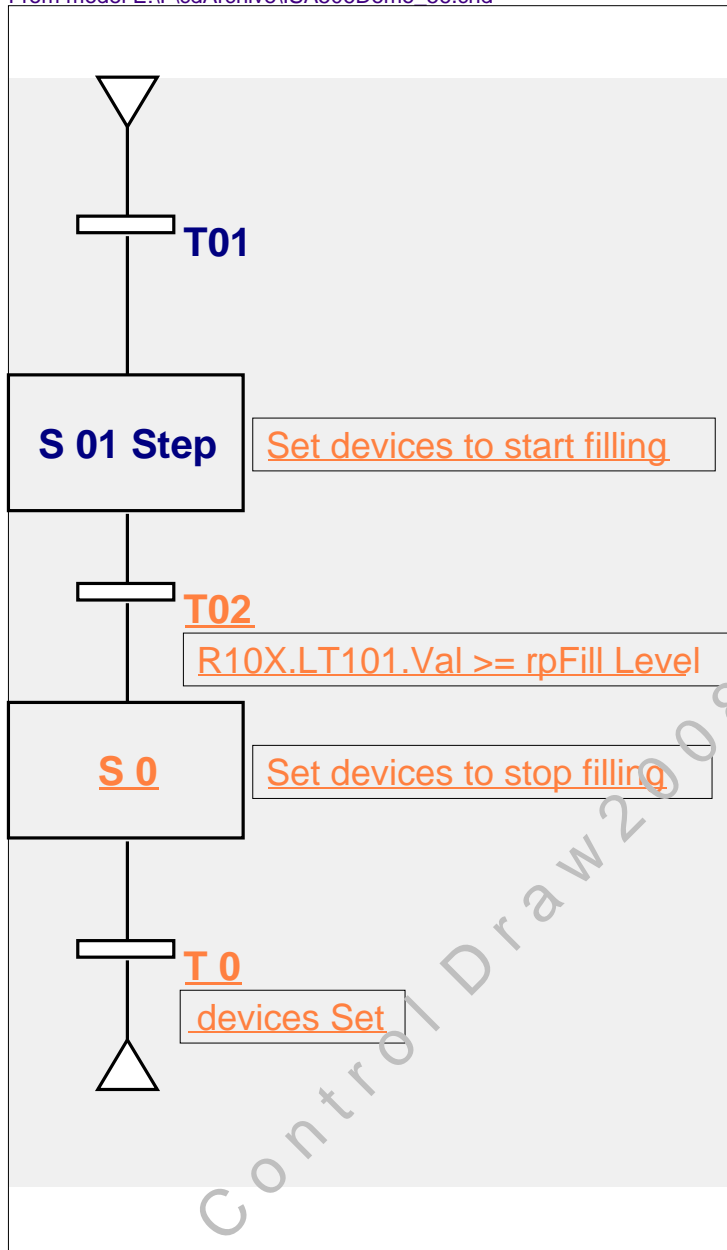
Variant 3 - C

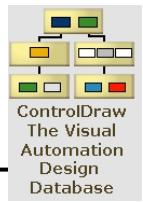


up7- rpFillQtyC



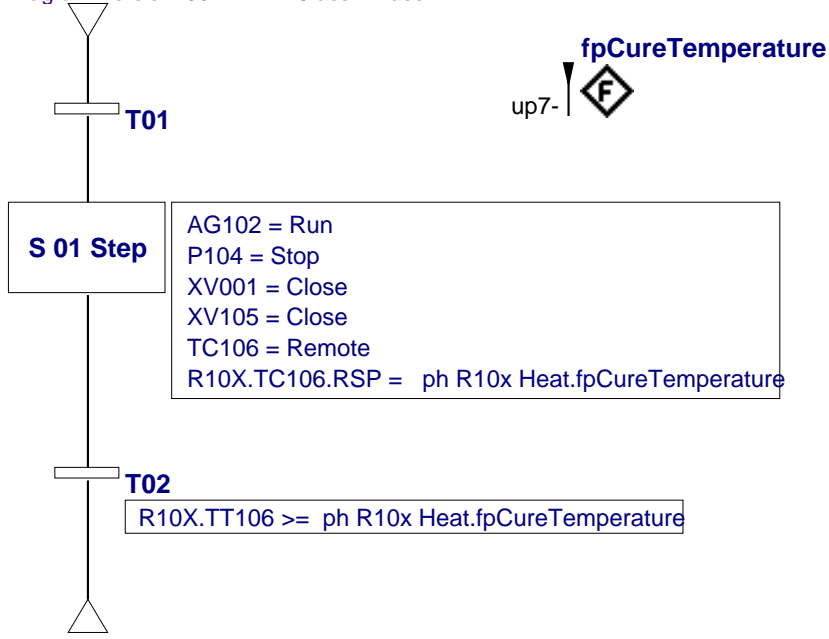
Previous diagram for Page 9, PageID 40  
Previous version, page 7, Version 34  
From model E:\FcdArchive\ISA506Demo\_56.cnd



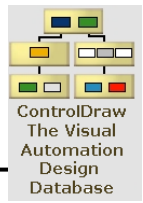


**Diagram 10 - ph R10x Heat**

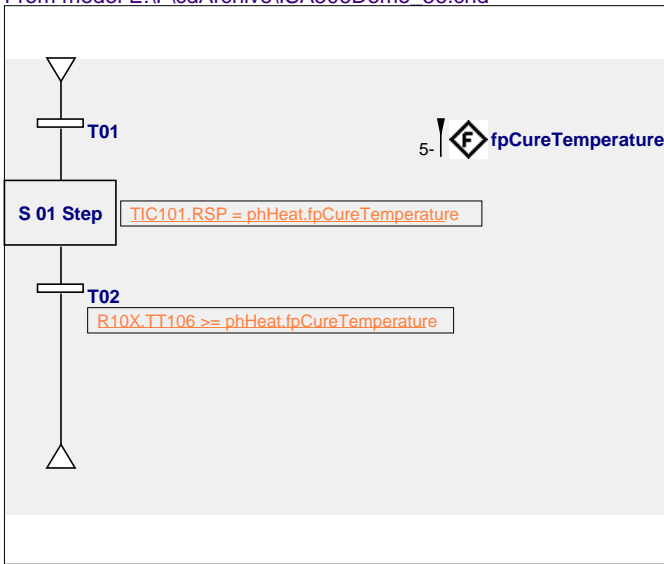
Diagram Version: 90      Class: Phase



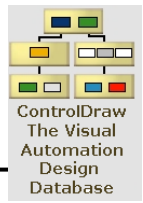
Control Draw 2008



Previous diagram for Page 10, PageID 41  
Previous version, page 8, Version 40  
From model E:\FcdArchive\ISA506Demo\_56.cnd

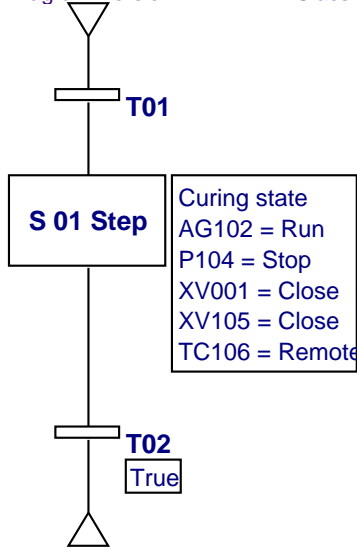


Control Draw 2008



**Diagram 11 - ph R10x Cure**

Diagram Version: 71      Class: Phase



up7- | **F** rpCureTime

up7- | **F** fpCureTemperature

Diagram did not exist in previous version of the model

Control Draw 2008

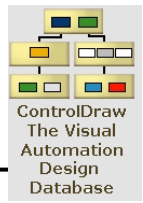
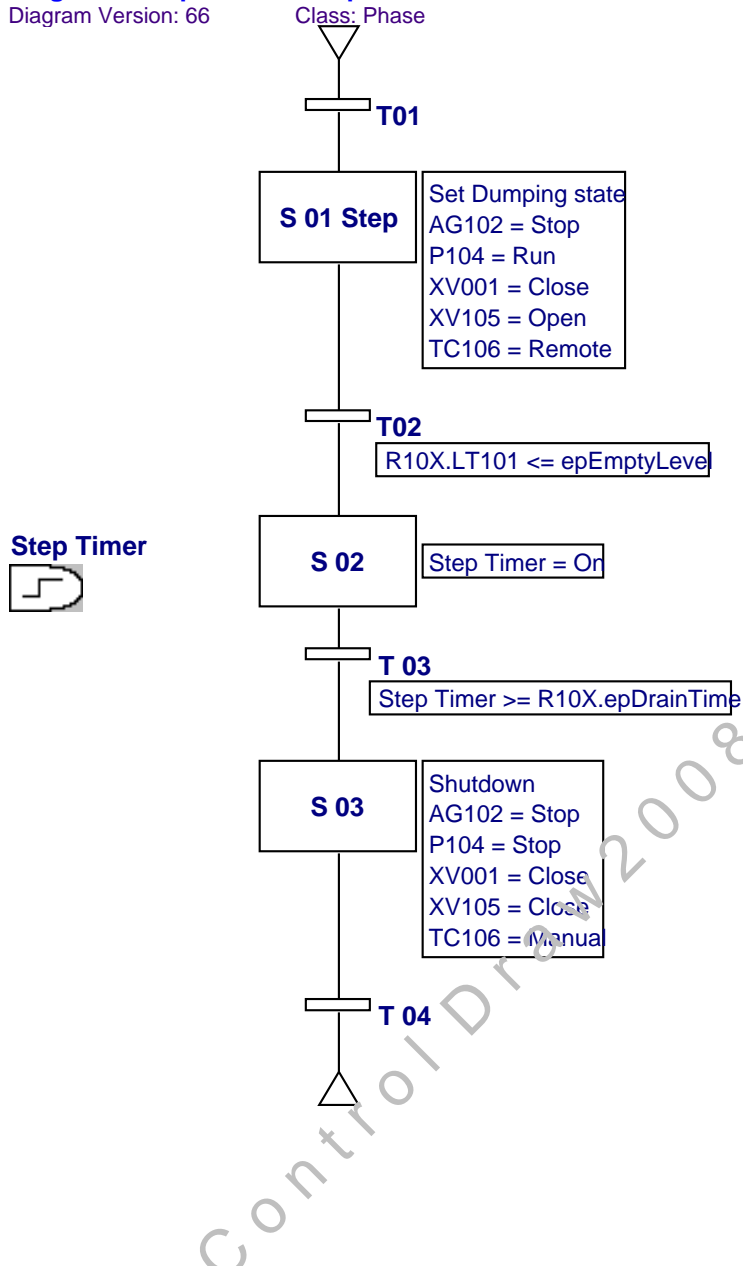


Diagram 12 - ph R10x Dump

Diagram Version: 66

Class: Phase

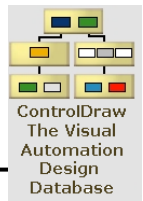


Step Timer



ControlDraw 2008

Diagram did not exist in previous version of the model



**Diagram 13 - UC102**

Diagram Version: 93

Class: Interlock Control Module

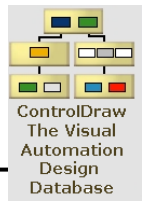


**HS**

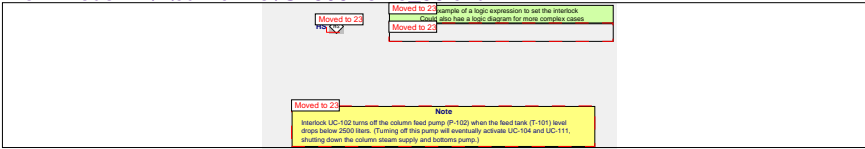
Manual override

If the liquid level is too low interlocks UC-102 and UC-104 will shut off the mixer and pump.

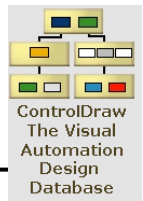
Control Draw 2008



Previous diagram for Page 13, PageID 38  
Previous version, page 9, Version 25  
From model E:\FcdArchive\ISA506Demo\_56.cnd



Control Draw 2008



**Diagram 14 - UC003**

Diagram Version: 91

Class: Interlock Control Module

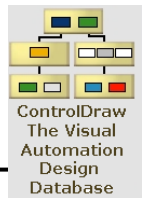


**{HS-004 CMD = CLOSED \*}**  
{HS-004 CMD = CLOSED \*}  
OR {HS-004 INPUT = MISALIGNED \*} OR  
{FQ-003 > RECIPE SP  
(FQSH-003 ON)}

P003.Interlock Condition = (UC003.HS = CLOSED) Or  
- 4 INPUT = MISALIGNED Or  
FQ - > RECIPE SP  
FQSH - 3 ON

Previous diagram for Page 14, PageID 28  
Previous version, page 10, Version 37  
From model E:\FcdArchive\ISA506Demo\_56.cnd  
Different version but no visible changes

Control Draw 2008



**Diagram 15 - UC104**

Diagram Version: 91      Class: Interlock Control Module

**Note**

Interlock UC-104 closes the reboiler steam valve (TV-104) if the column level drops below the 5% value or if the condenser cooling water flow slows (FAL-106).

Diagram did not exist in previous version of the model

Control Draw 2008

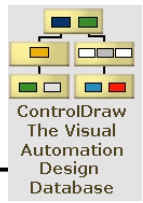
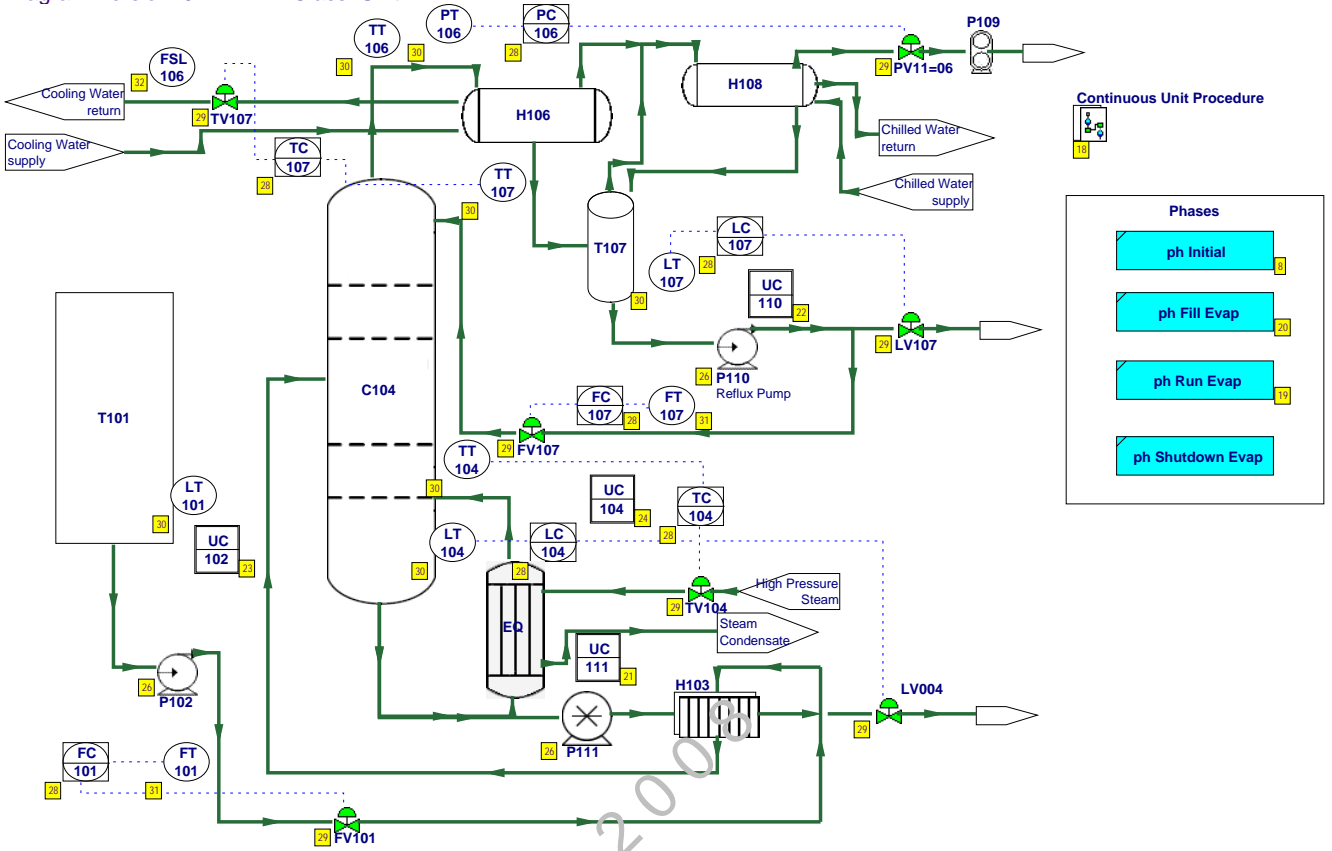


Diagram 16 - C104

Diagram Version: 91

Class: Unit

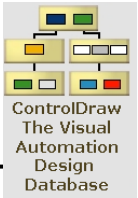


**Continuous Unit Procedure**

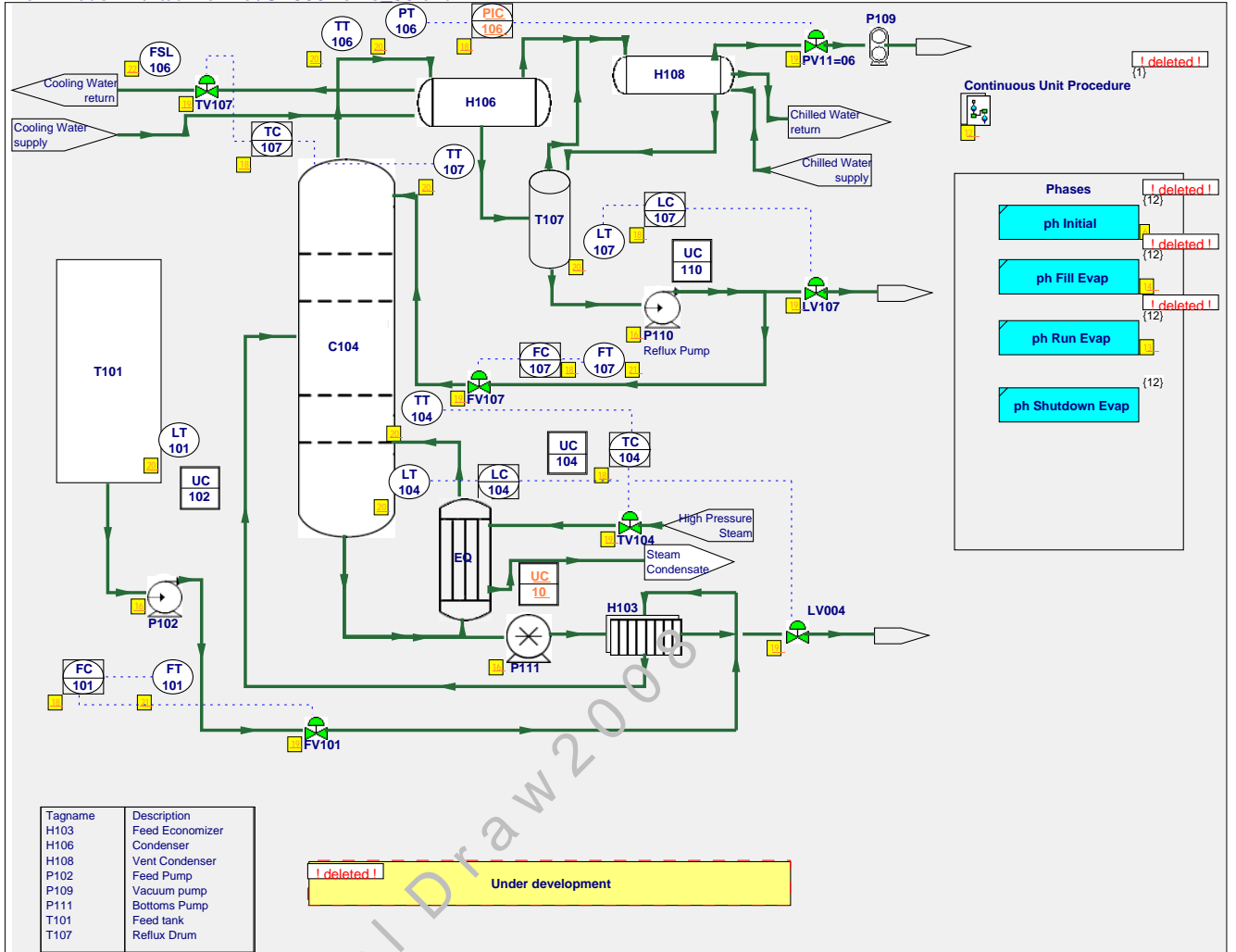
Phases

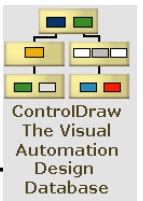
- ph Initial
- ph Fill Evap
- ph Run Evap
- ph Shutdown Evap

Tagname	Description
H103	Feed Economizer
H106	Condenser
H108	Vent Condenser
P102	Feed Pump
P109	Vacuum pump
P111	Bottoms Pump
T101	Feed tank
T107	Reflux Drum



Previous diagram for Page 16, PageID 25  
 Previous version, page 11, Version 55  
 From model E:\FcdArchive\ISA506Demo\_56.cnd





**Diagram 17 - RP\_C**

Diagram Version: 85

Class: Recipe Procedure

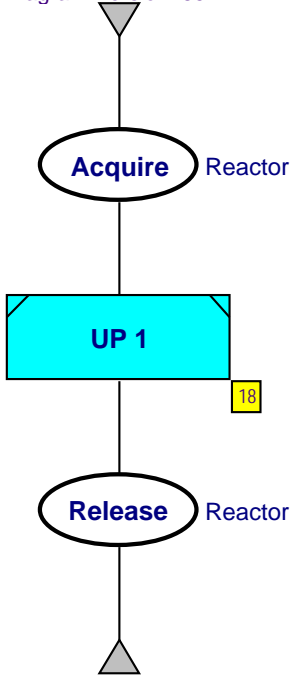
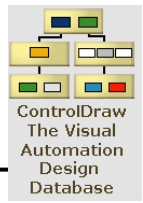


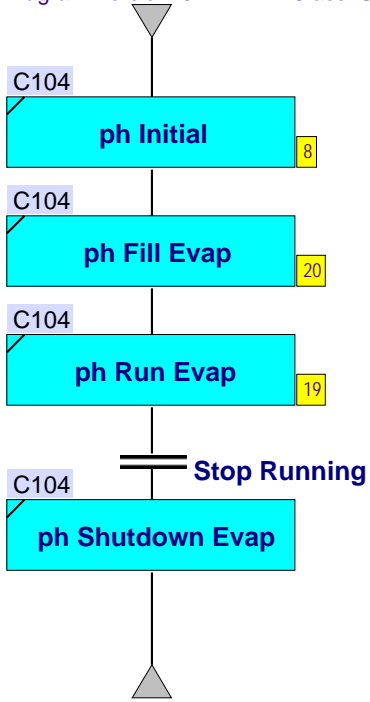
Diagram did not exist in previous version of the model

Control Draw 2008



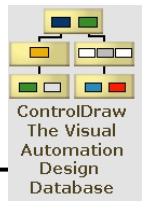
**Diagram 18 - Continuous Unit Procedure**

Diagram Version: 52      Class: Unit Procedure



Previous version is same as current, 52

Control Draw 2008



**Diagram 19 - ph Run Evap**

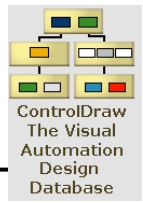
Diagram Version: 52      Class: Phase

This phase just runs until the unit has to shut down



Previous version is same as current, 52

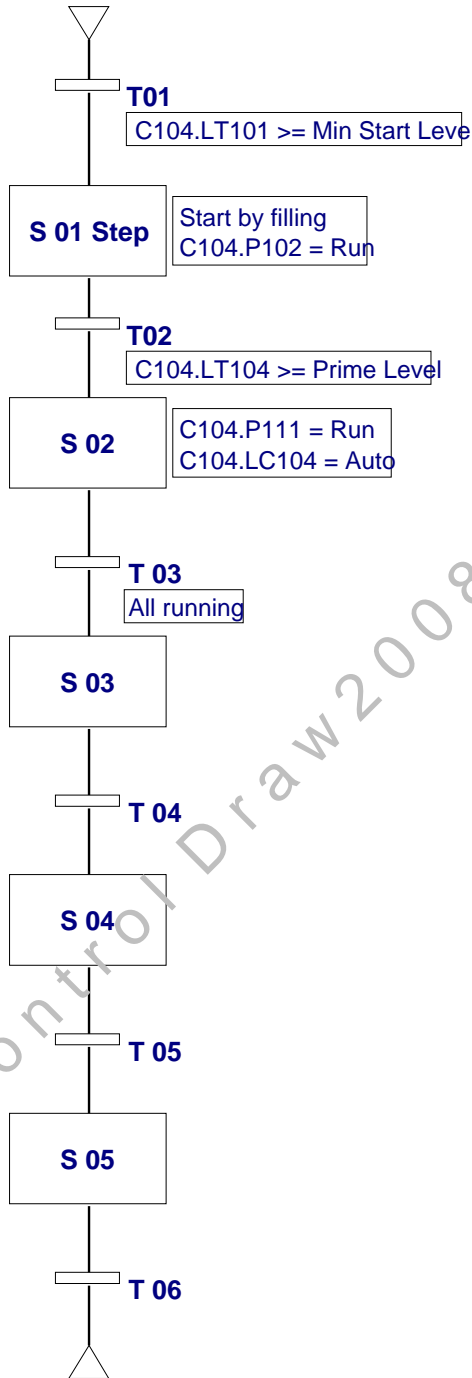
Control Draw 2008



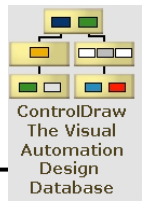
**Diagram 20 - ph Fill Evap**

Diagram Version: 55      Class: Phase

This is just an example and only the first few steps.. Even those may not be sensible!



Previous version is same as current, 55



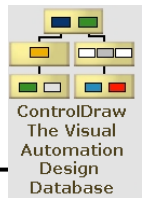
**Diagram 21 - UC111**

Diagram Version: 91      Class: Interlock Control Module

Interlock UC-111 turns off the bottoms pump (P-111) if the column level drops below the 5% value.

Diagram did not exist in previous version of the model

Control Draw 2008



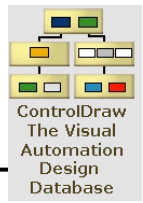
**Diagram 22 - UC110**

Diagram Version: 91      Class: Interlock Control Module

Interlock UC-110 turns off the reflux pump (P-110) when the reflux drum level (LIC-107) reaches 10%.

Diagram did not exist in previous version of the model

Control Draw 2008



**Diagram 23 - UC102 (Column)**

Diagram Version: 93

Class: Interlock Control Module

P102.Interlock Condition = (LT101.Val <= epMinPumpLevel ) Or UC102.HS



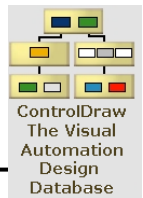
**HS**  
Manual override

**Note**

Interlock UC-102 turns off the column feed pump (P-102) when the feed tank (T-101) level drops below 2500 liters. (Turning off this pump will eventually activate UC-104 and UC-111, shutting down the column steam supply and bottoms pump.)

Diagram did not exist in previous version of the model

Control Draw 2008



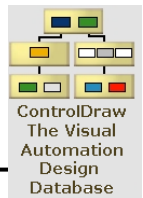
**Diagram 24 - UC104 (Column)**

Diagram Version: 91      Class: Interlock Control Module

Interlock UC-104 closes the reboiler steam valve (TV-104) if the column level drops below the 5% value or if the condenser cooling water flow slows (FAL-106)

Diagram did not exist in previous version of the model

Control Draw 2008

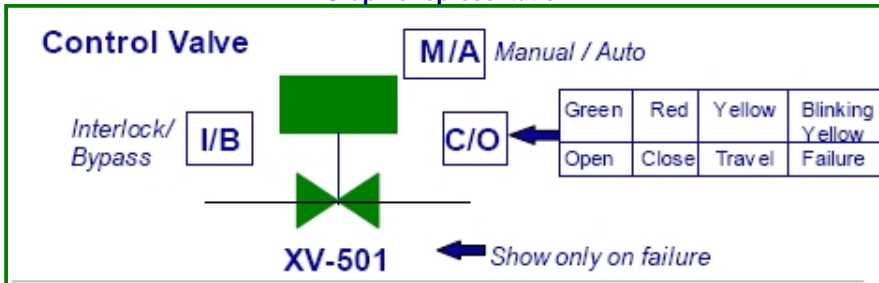


**Diagram 25 - On Off Valve**

Diagram Version: 89 Class: Valve

**Variant 2 - Closed LS**

Graphic representation



PCNode  
Inst: Text  
Default: !Inherit

TMRO  
Inst: Single  
Default: 5

TMRC  
Inst: Single  
Default: 2

Test object  
Field  
Obj: Text

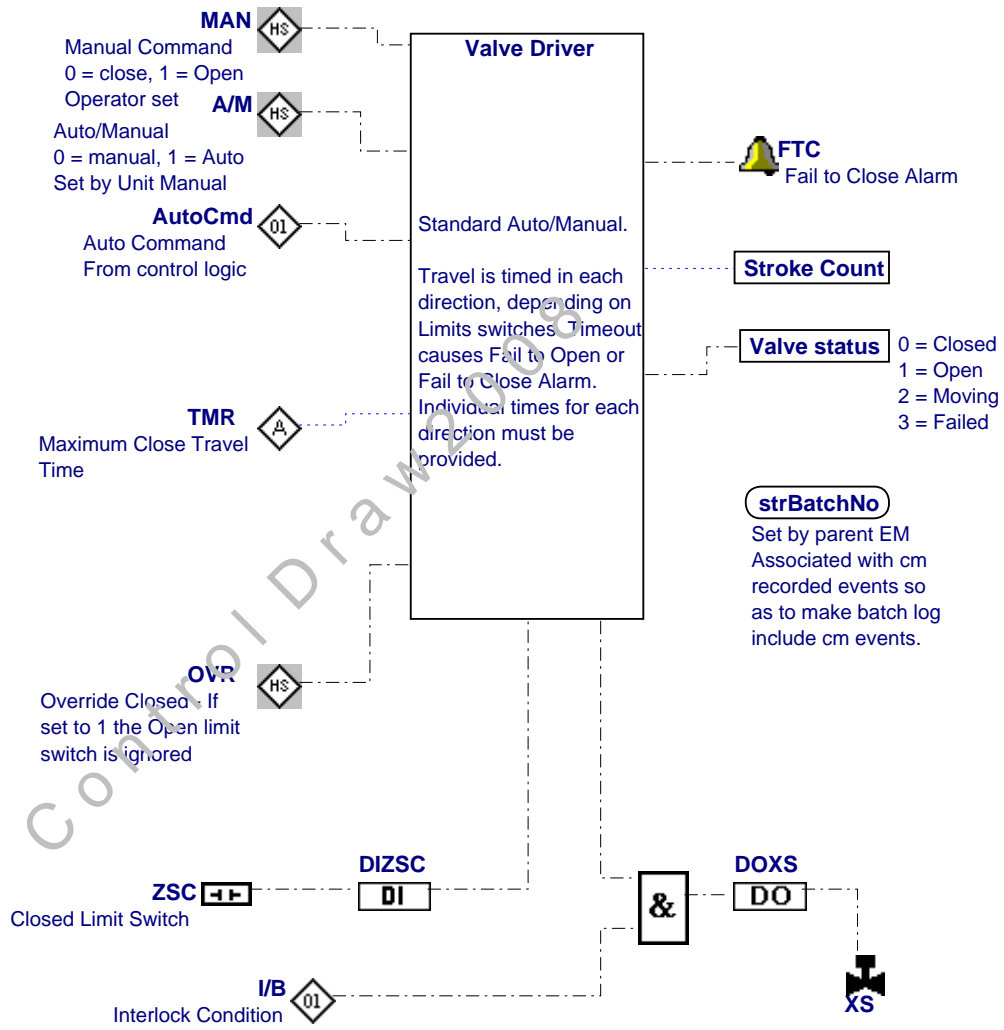
CM Tag  
Inst: Text

FailOpen  
Inst: Boolean

Type  
Inst: Text

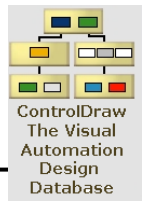
Signed  
Test Sheet  
Table

Tested  
Test Sheet  
Table



List of Variants

	1-Open LS	2-Closed LS	3-2 Limit Switches	4-No limit switches
DIZSC	{Excluded}			{Excluded}
DIZSO		{Excluded}		{Excluded}
FTC	{Excluded}			{Excluded}
FTO		{Excluded}		{Excluded}
OVRC	{Excluded}	OVR		{Excluded}
OVRO	OVR	{Excluded}		{Excluded}
TMRC	{Excluded}	TMR		{Excluded}
TMRO	TMR	{Excluded}		{Excluded}
ZSC	{Excluded}			{Excluded}
ZSO		{Excluded}		{Excluded}

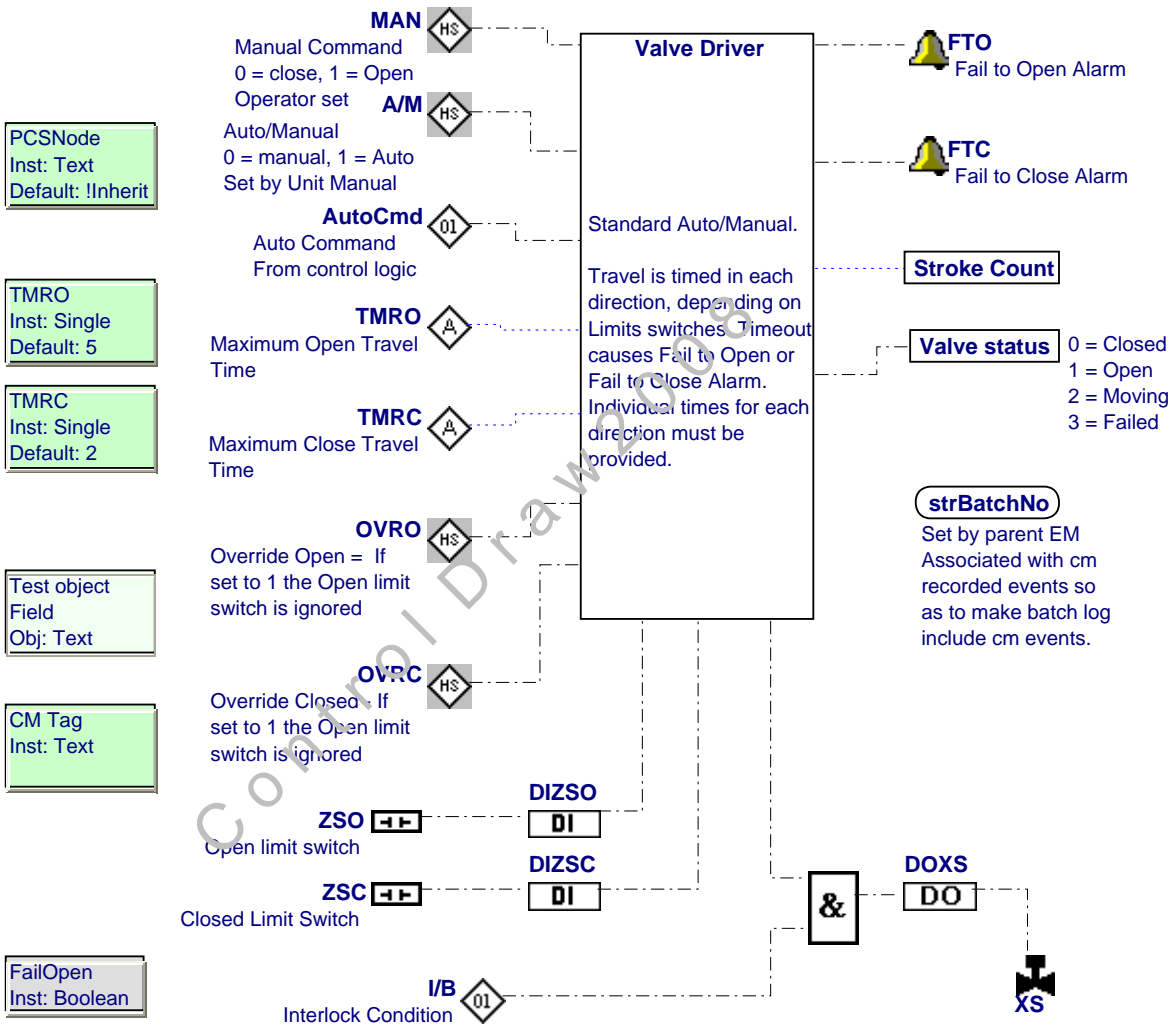
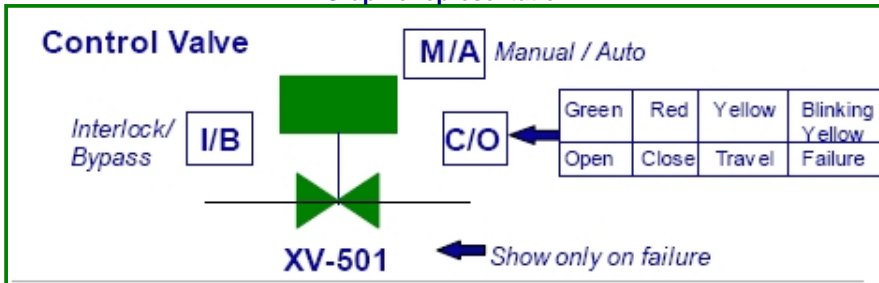


**Diagram 25 - On Off Valve**

Diagram Version: 89 Class: Valve

**Variant 3 - 2 Limit Switches**

Graphic representation



PCNode  
Inst: Text  
Default: !Inherit

TMRO  
Inst: Single  
Default: 5

TMRC  
Inst: Single  
Default: 2

Test object  
Field  
Obj: Text

CM Tag  
Inst: Text

FailOpen  
Inst: Boolean

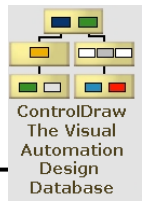
Type  
Inst: Text

Signed  
Test Sheet  
Table

Tested  
Test Sheet  
Table

List of Variants

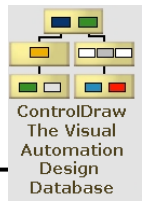
	1-Open LS	2-Closed LS	3-2 Limit Switches	4-No limit switches
DIZSC	{Excluded}			{Excluded}
DIZSO		{Excluded}		{Excluded}
FTC	{Excluded}			{Excluded}
FTO		{Excluded}		{Excluded}
OVRC	{Excluded}	OVR		{Excluded}
OVRO	OVR	{Excluded}		{Excluded}
TMRC	{Excluded}	TMR		{Excluded}
TMRO	TMR	{Excluded}		{Excluded}
ZSC	{Excluded}			{Excluded}
ZSO		{Excluded}		{Excluded}



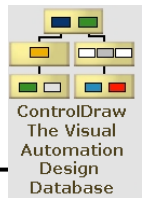
---

Previous diagram for Page 25, PageID 11  
Previous version, page 15, Version 24  
From model E:\FcdArchive\ISA506Demo\_56.cnd  
Different version but no visible changes

Control Draw 2008



Control Draw 2008



**Diagram 26 - Fixed Speed Motor**

Diagram Version: 89

Class: Motor

Graphic representation

**Motor**

Interlock/  
Bypass

I/B

M/A

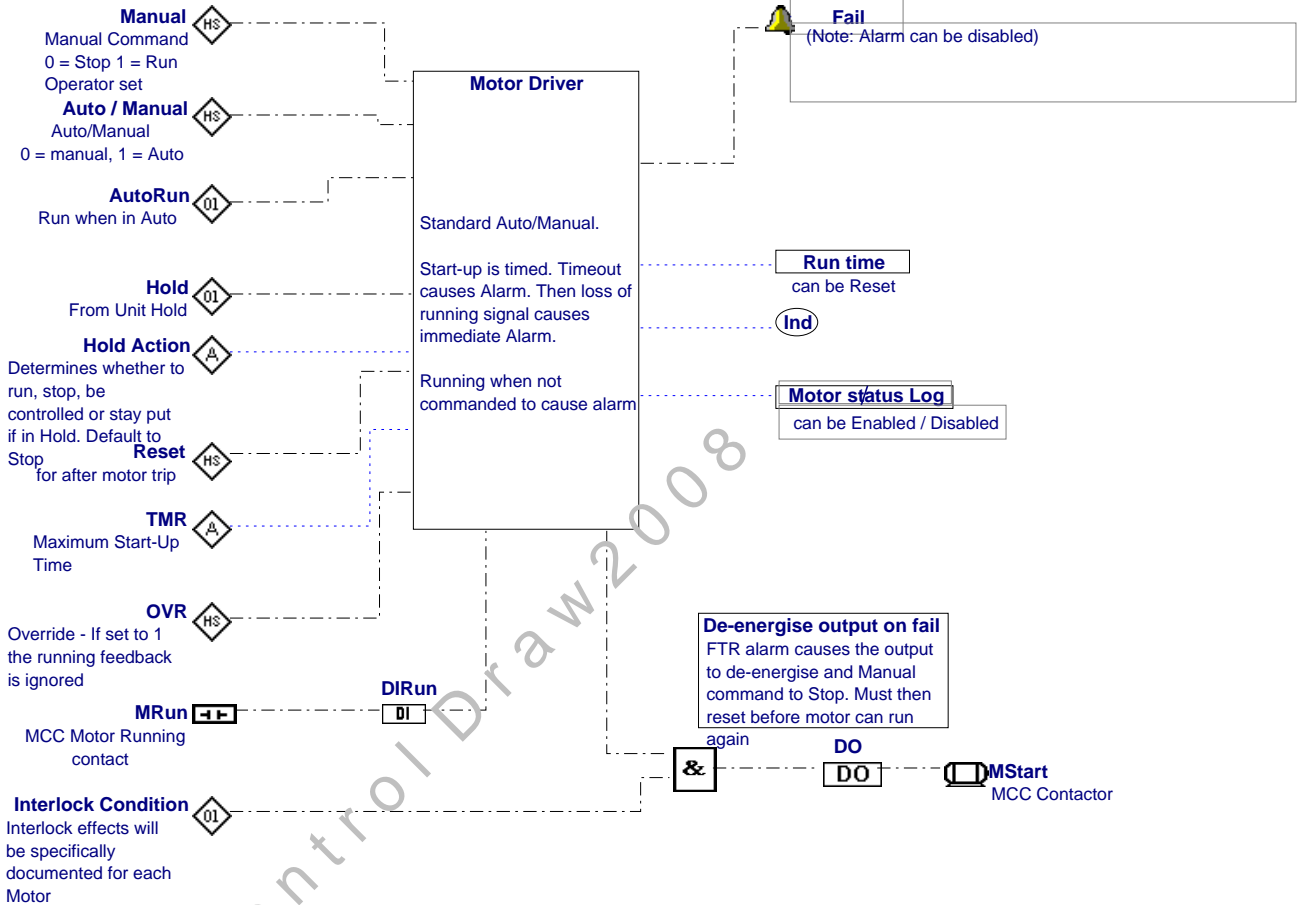
Manual / Auto



S/R

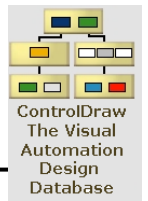
Green	Red	Blinking Yellow
Run	Stop	Failure

**XM-601**

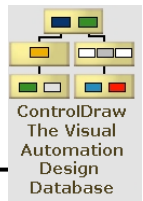


Logged Inst: Boolean	Signed Test Sheet Table	VSD Inst: Boolean	Power Inst: Single	Power Units Inst: Text Default: Kw	PCNode Inst: Text Default: !Inherit
RPM Inst: Text	Tested Test Sheet Table	CM Tag Inst: Text Default: !Sc_CM			

Previous diagram for Page 26, PageID 12  
 Previous version, page 16, Version 13  
 From model E:\FcdArchive\ISA506Demo\_56.cnd  
 Different version but no visible changes



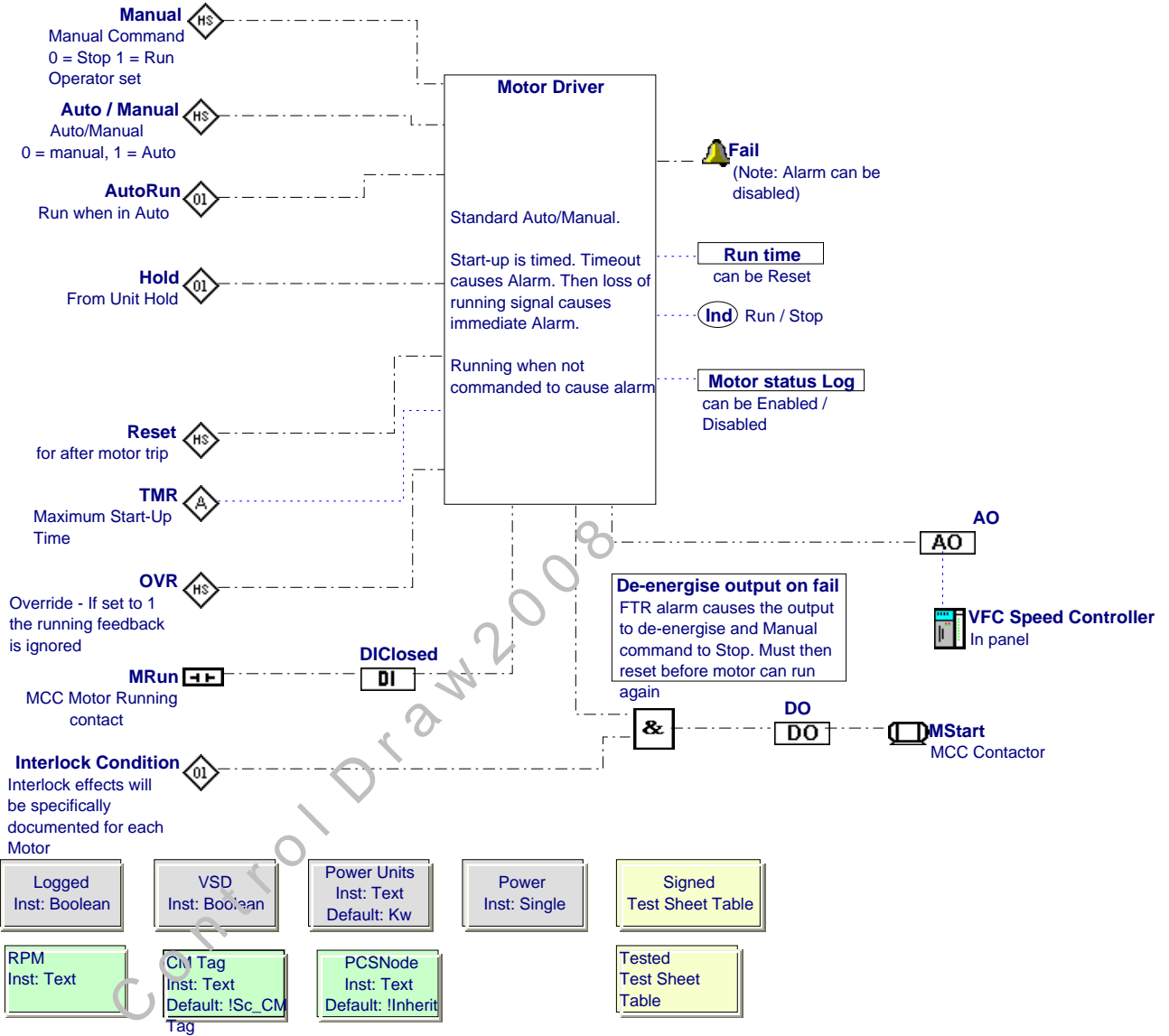
Control Draw 2008

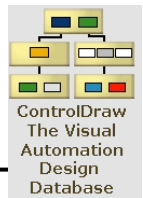


**Diagram 27 - Variable Speed motor**

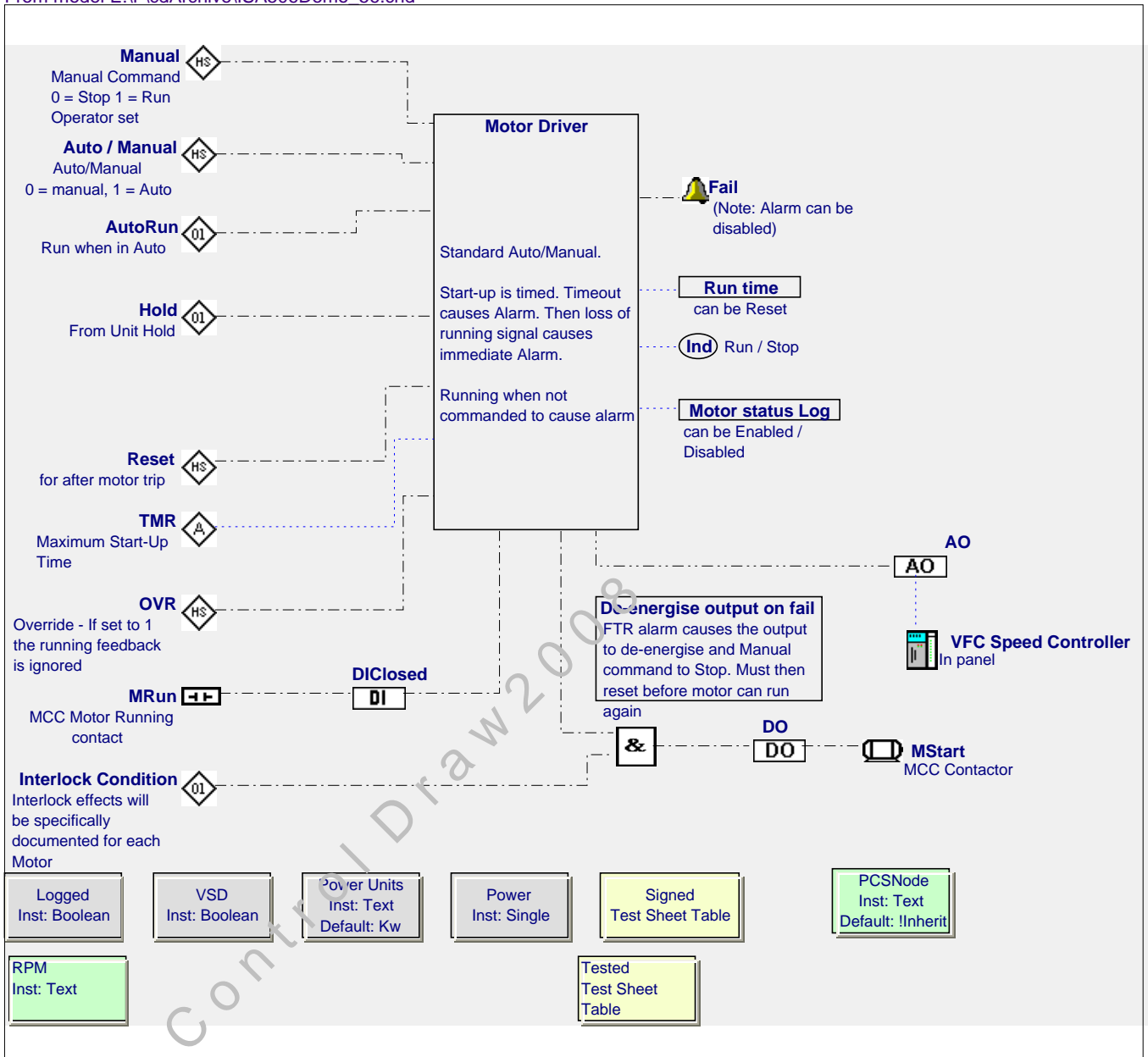
Diagram Version: 90 Class: Motor

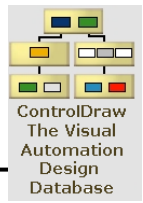
S88 Class	Name
Control Module	Variable Speed motor





Previous diagram for Page 27, PageID 13  
 Previous version, page 17, Version 1  
 From model E:\FcdArchive\ISA506Demo\_56.cnd

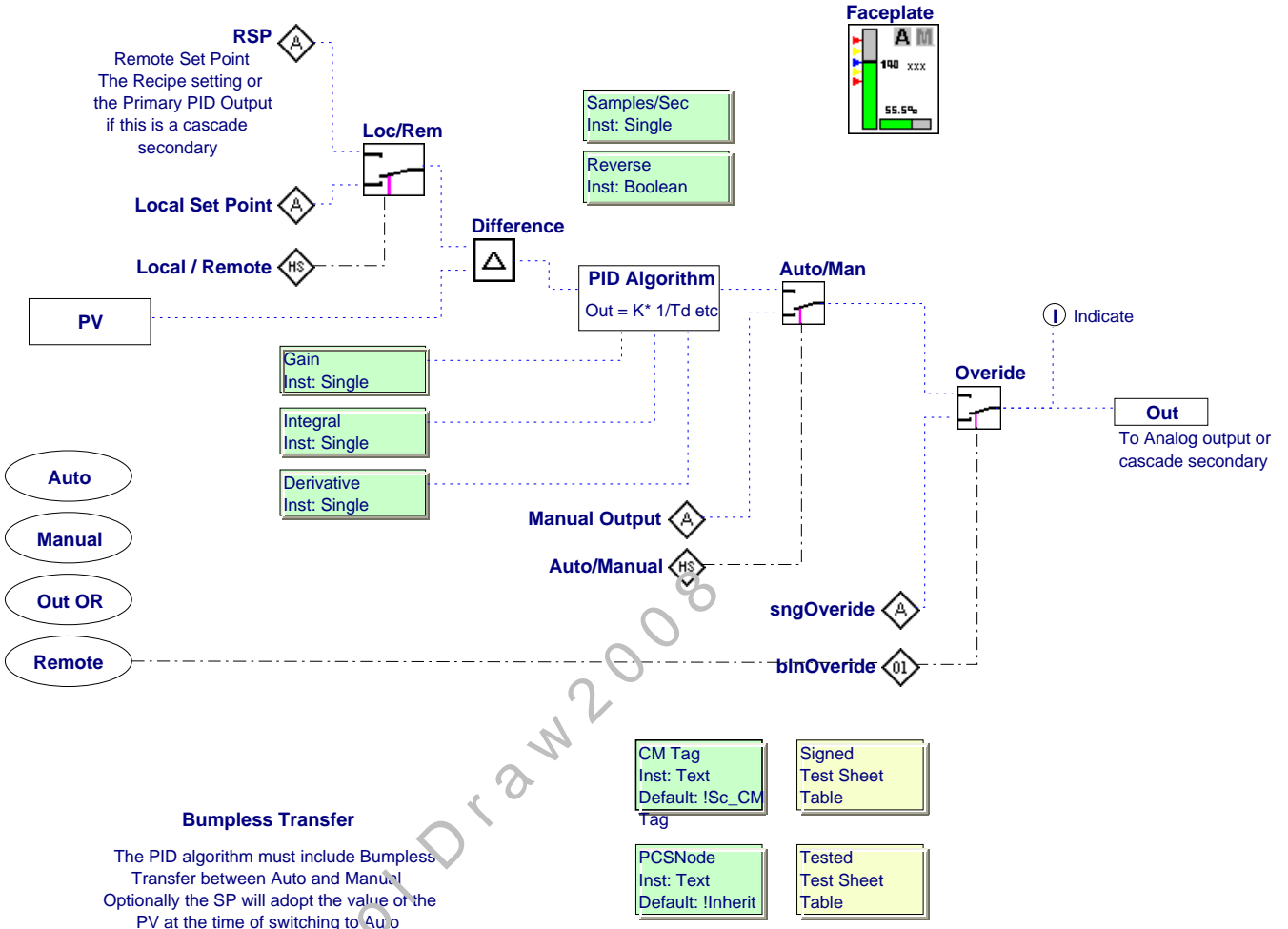


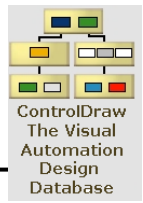


**Diagram 28 - Standard PID Loop**

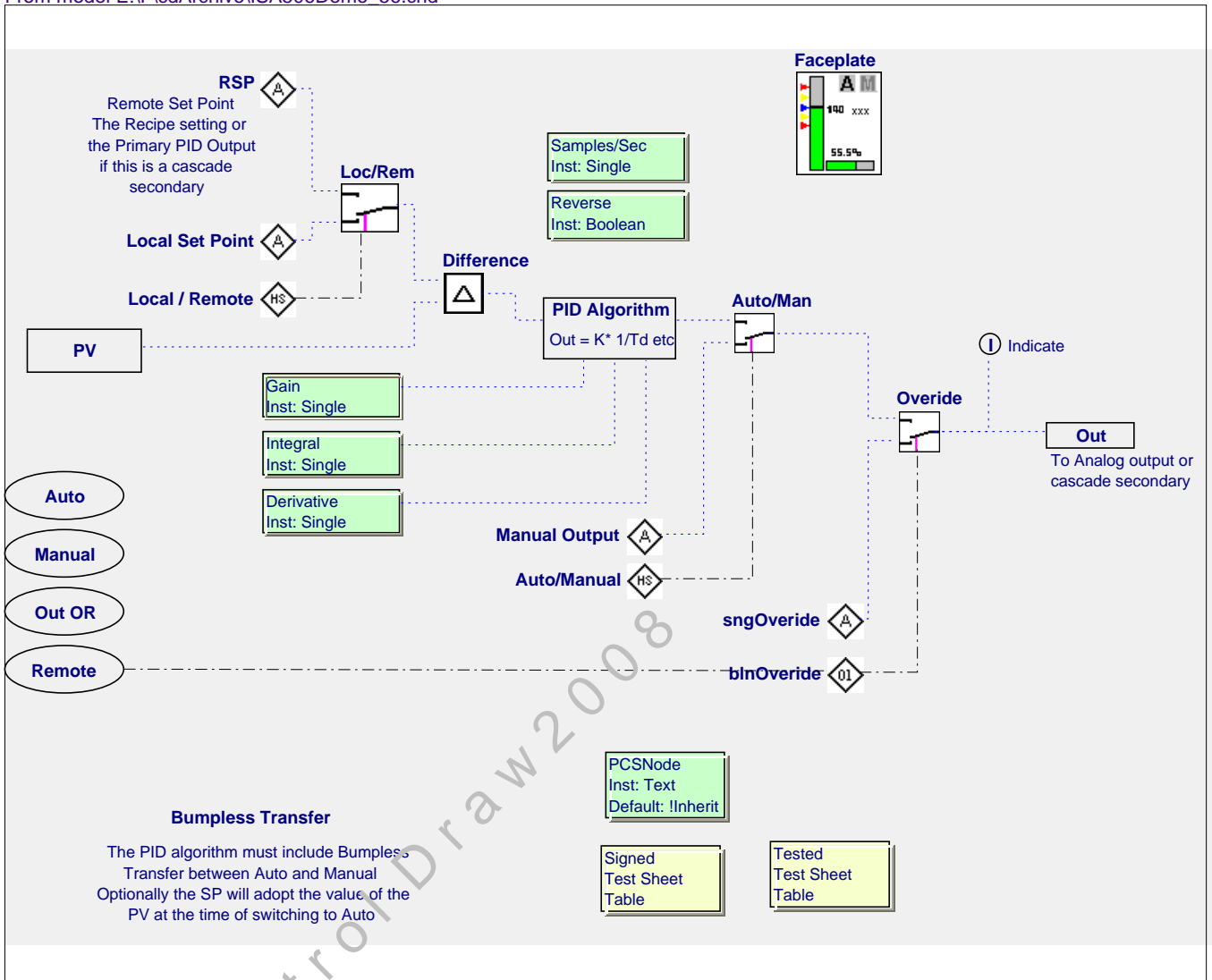
Diagram Version: 90      Class: PID Control Loop

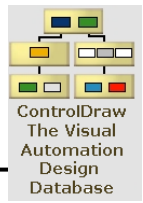
S88 Class	Name
Control Module	Standard PID Loop





Previous diagram for Page 28, PageID 15  
 Previous version, page 18, Version 9  
 From model E:\FcdArchive\ISA506Demo\_56.cnd

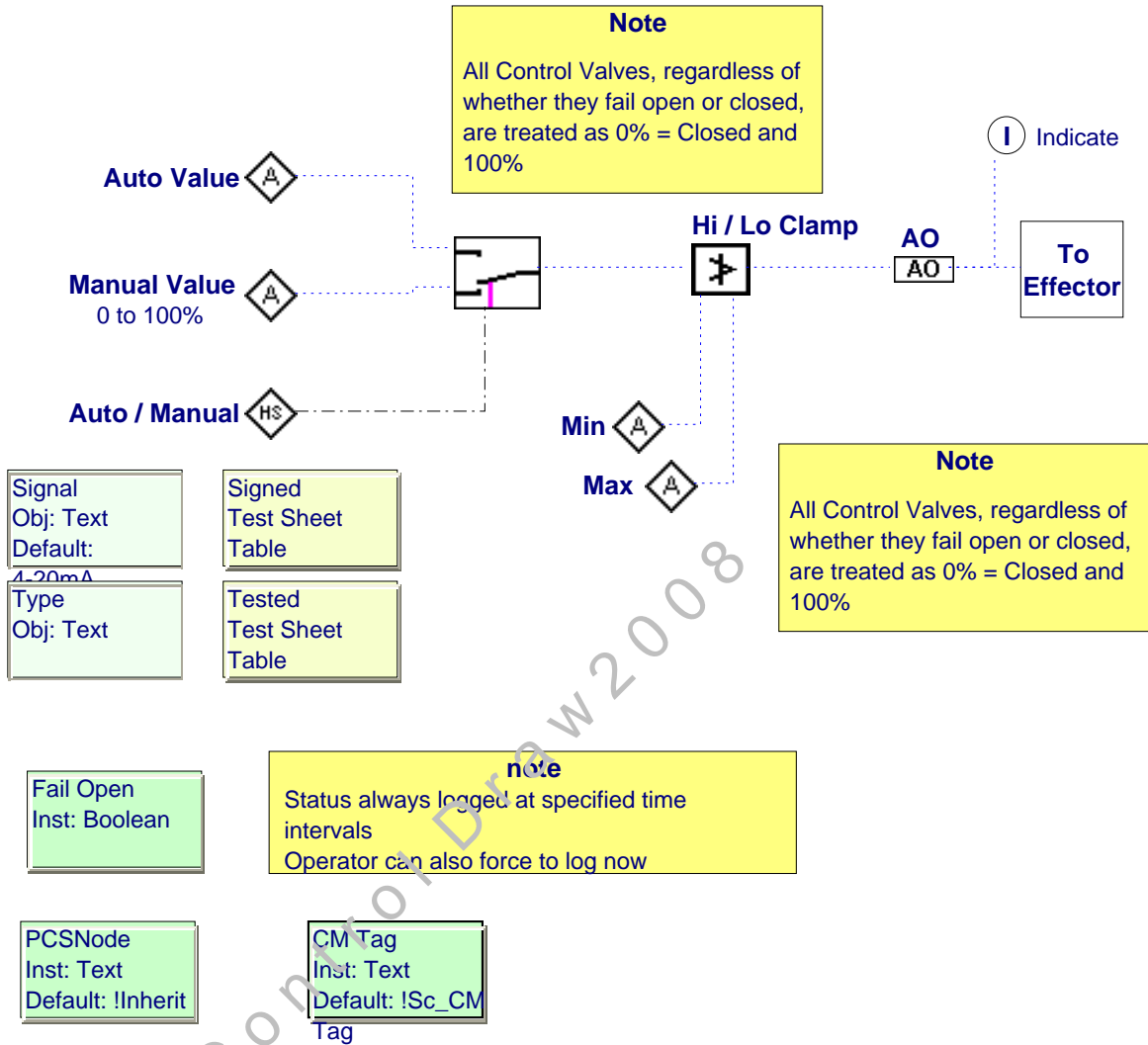


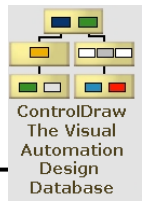


**Diagram 29 - Control Valve**

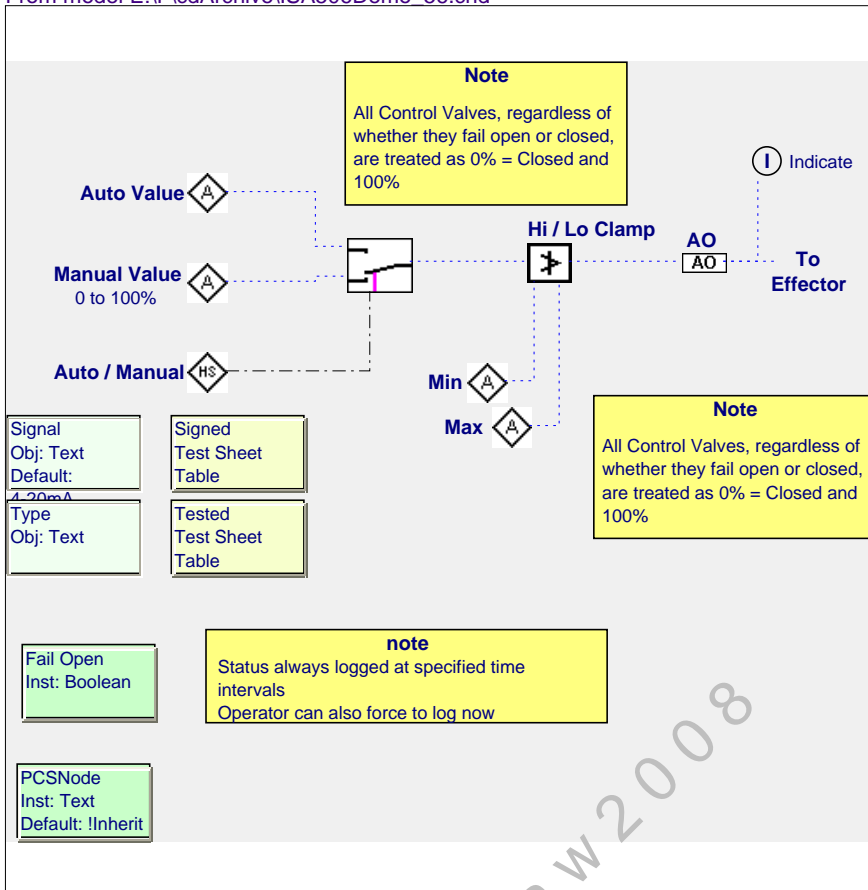
Diagram Version: 90      Class: Effector Analog

S88 Class	Name
Control Module	Control Valve

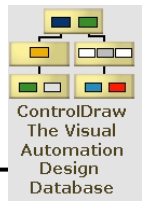




Previous diagram for Page 29, PageID 16  
 Previous version, page 19, Version 49  
 From model E:\FcdArchive\ISA506Demo\_56.cnd



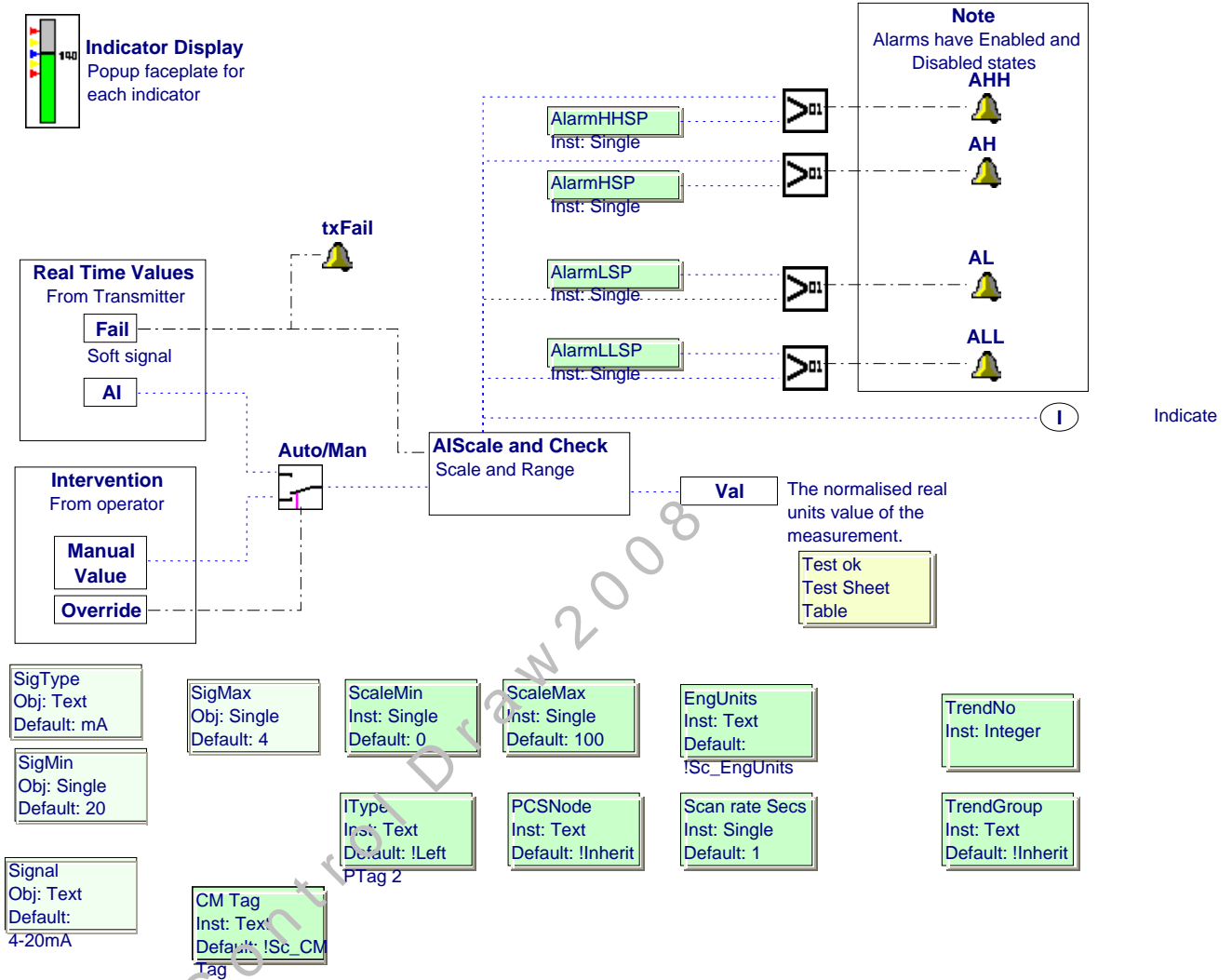
Control Draw 2008

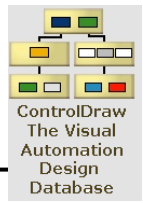


**Diagram 30 - Analog Input from Transmitter**

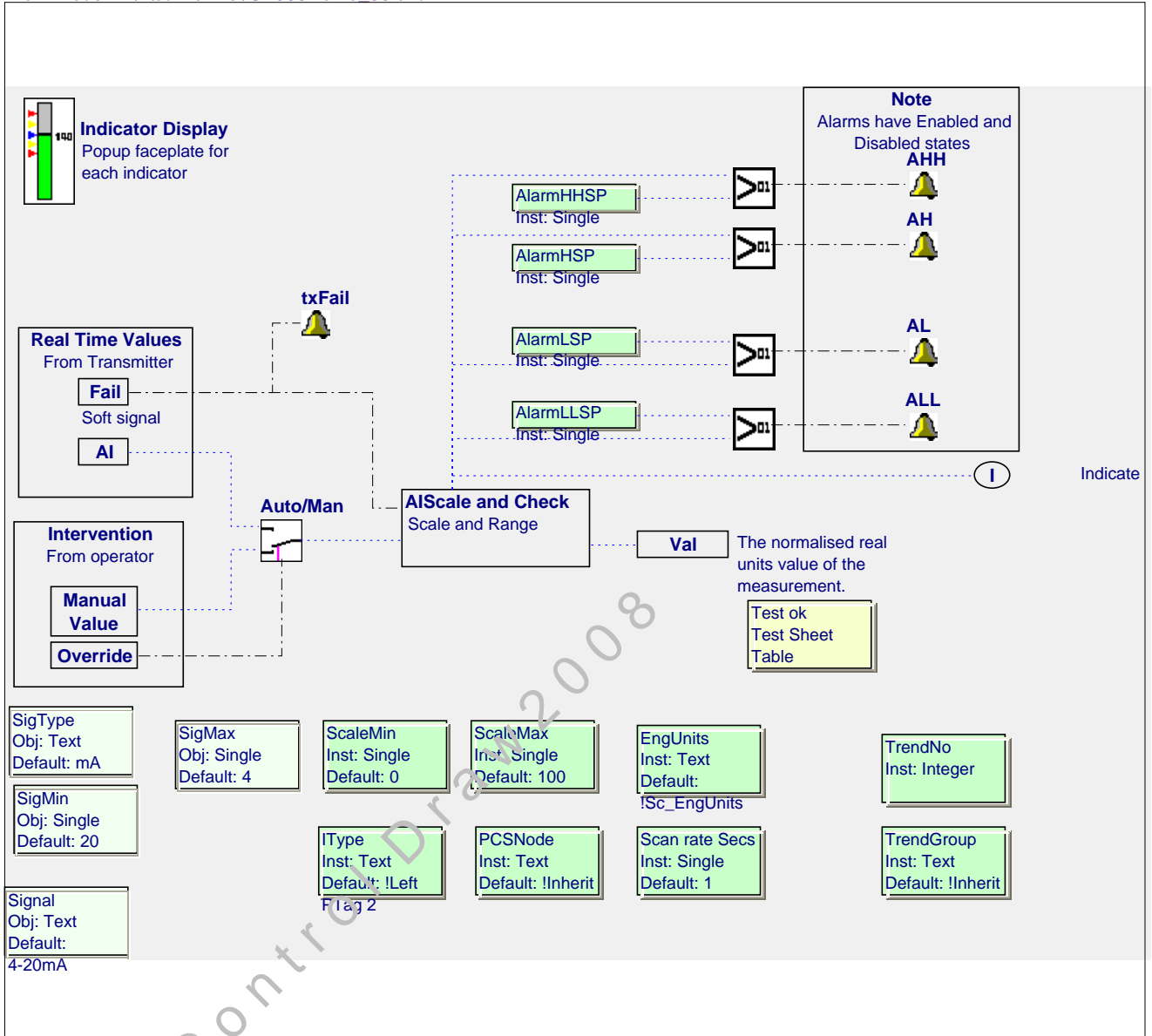
Diagram Version: 90 Class: Measurement Analog

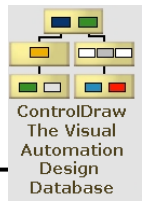
S88 Class	Name
Control Module	Analog Input from Transmitter





Previous diagram for Page 30, PageID 17  
 Previous version, page 20, Version 49  
 From model E:\FcdArchive\ISA506Demo\_56.cnd

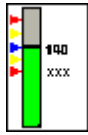




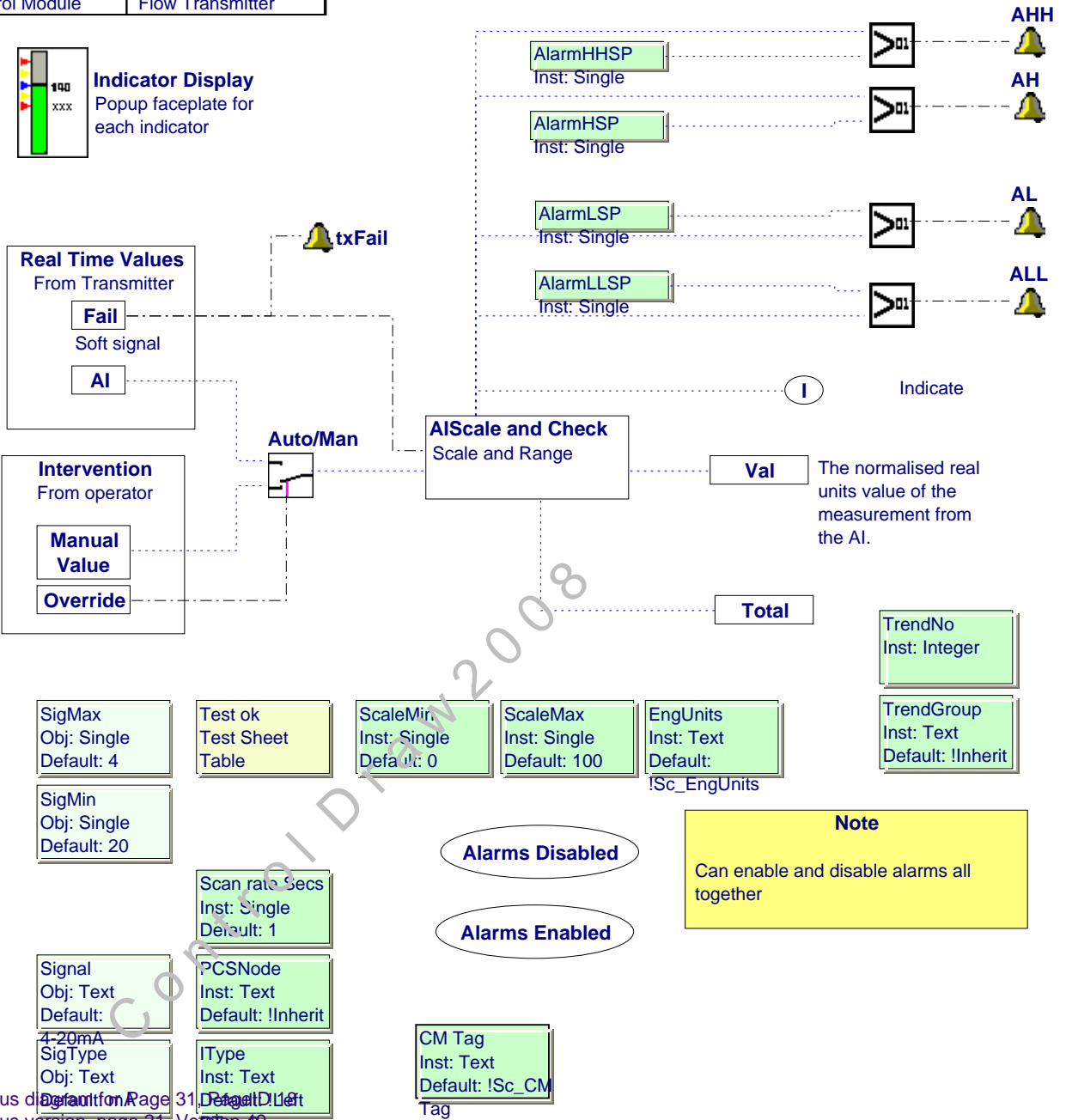
**Diagram 31 - Flow Transmitter**

Diagram Version: 90 Class: Measurement Analog

S88 Class	Name
Control Module	Flow Transmitter



**Indicator Display**  
Popup faceplate for each indicator



SigMax  
Obj: Single  
Default: 4

Test ok  
Test Sheet  
Table

ScaleMin  
Inst: Single  
Default: 0

ScaleMax  
Inst: Single  
Default: 100

EngUnits  
Inst: Text  
Default: !Sc\_EngUnits

SigMin  
Obj: Single  
Default: 20

Scan rate Secs  
Inst: Single  
Default: 1

Signal  
Obj: Text  
Default: 4-20mA

PCSNode  
Inst: Text  
Default: !Inherit

SigType  
Obj: Text  
Default: !Sc\_Dir

IType  
Inst: Text  
Default: !Sc\_Dir

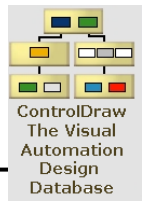
Alarms Disabled

Alarms Enabled

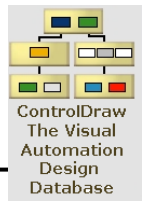
**Note**  
Can enable and disable alarms all together

CM Tag  
Inst: Text  
Default: !Sc\_CM Tag

Previous diagram on Page 31, Version 49  
Previous version, page 21, Version 49  
From model E:\FcdArchive\ISA506Demo\_56.cnd  
Different version but no visible changes



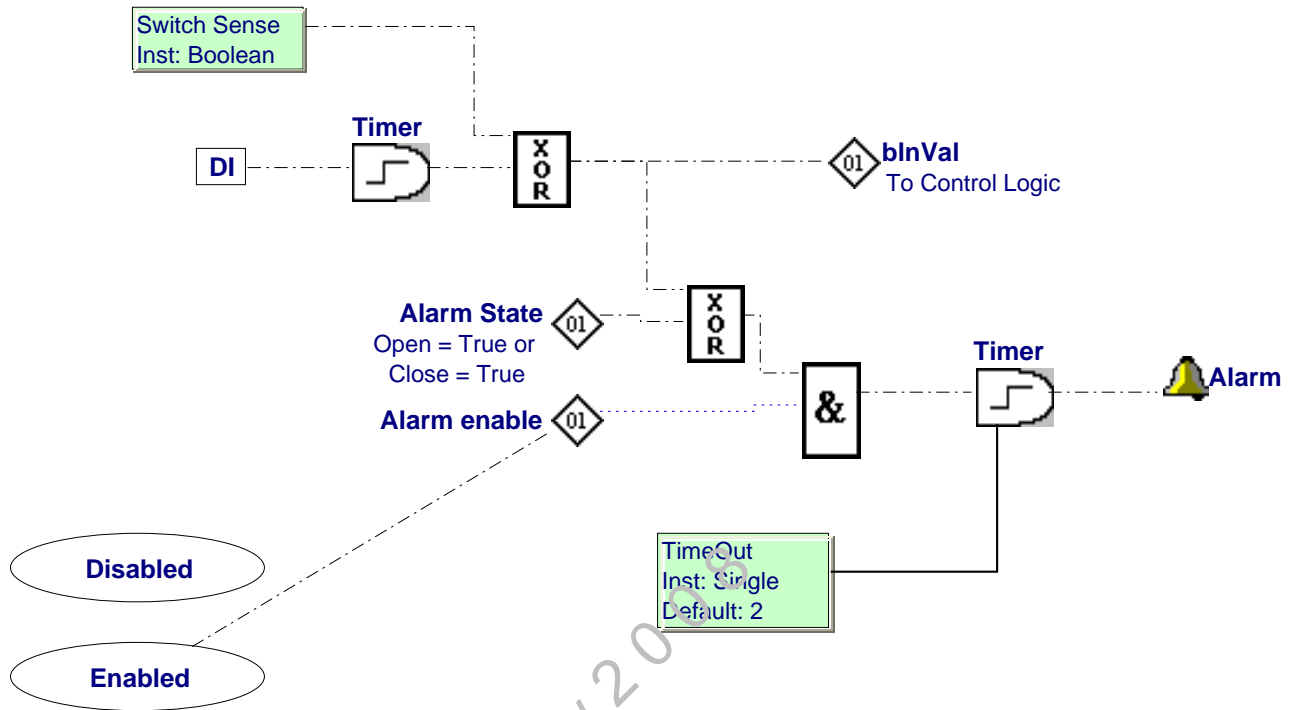
Control Draw 2008



**Diagram 32 - Alarm Switch Input**

Diagram Version: 91      Class: Measurement Switch

S88 Class	Name
Control Module	Alarm Switch Input



Signed  
Test Sheet  
Table

PCSNode  
Inst: Text  
Default: !Inherit

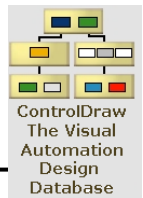
Type  
Obj: Text

TrendNo  
Inst: Integer

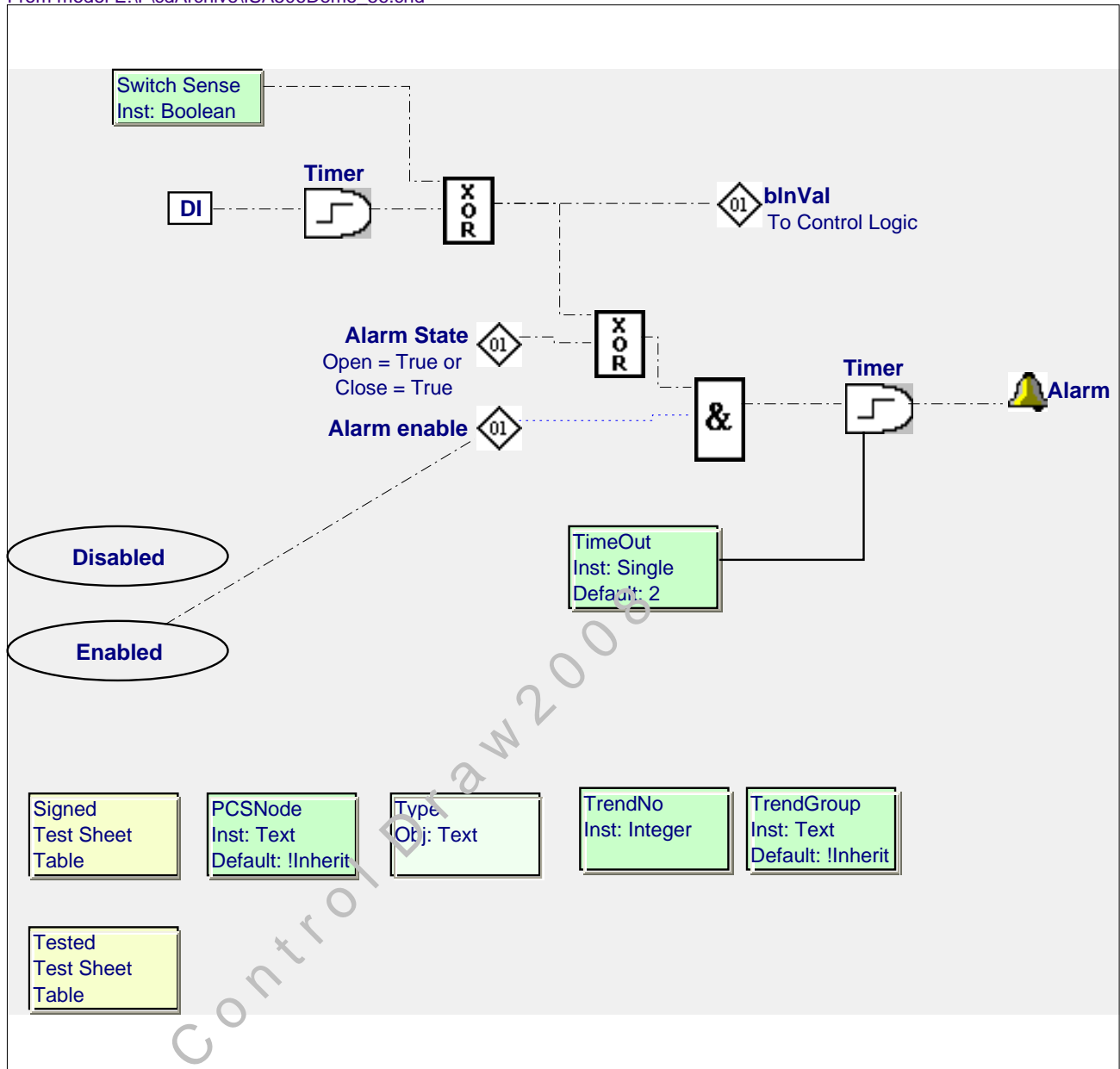
TrendGroup  
Inst: Text  
Default: !Inherit

Tested  
Test Sheet  
Table

CM Tag  
Inst: Text  
Default: !Sc\_CM  
Tag



Previous diagram for Page 32, PageID 43  
Previous version, page 22, Version 50  
From model E:\FcdArchive\ISA506Demo\_56.cnd



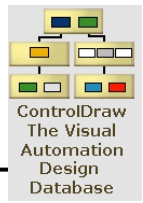
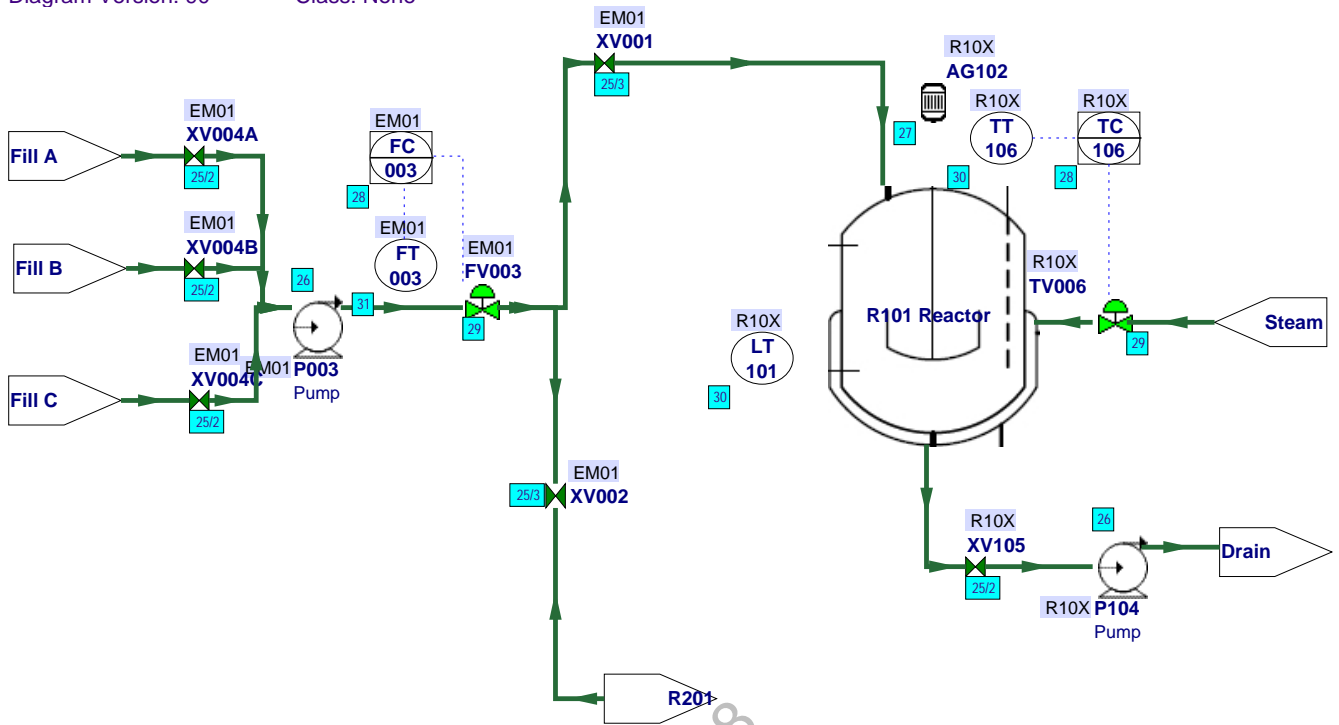


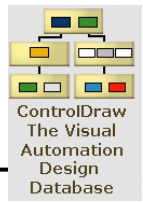
Diagram 33 - Complete Graphic

Diagram Version: 90 Class: None

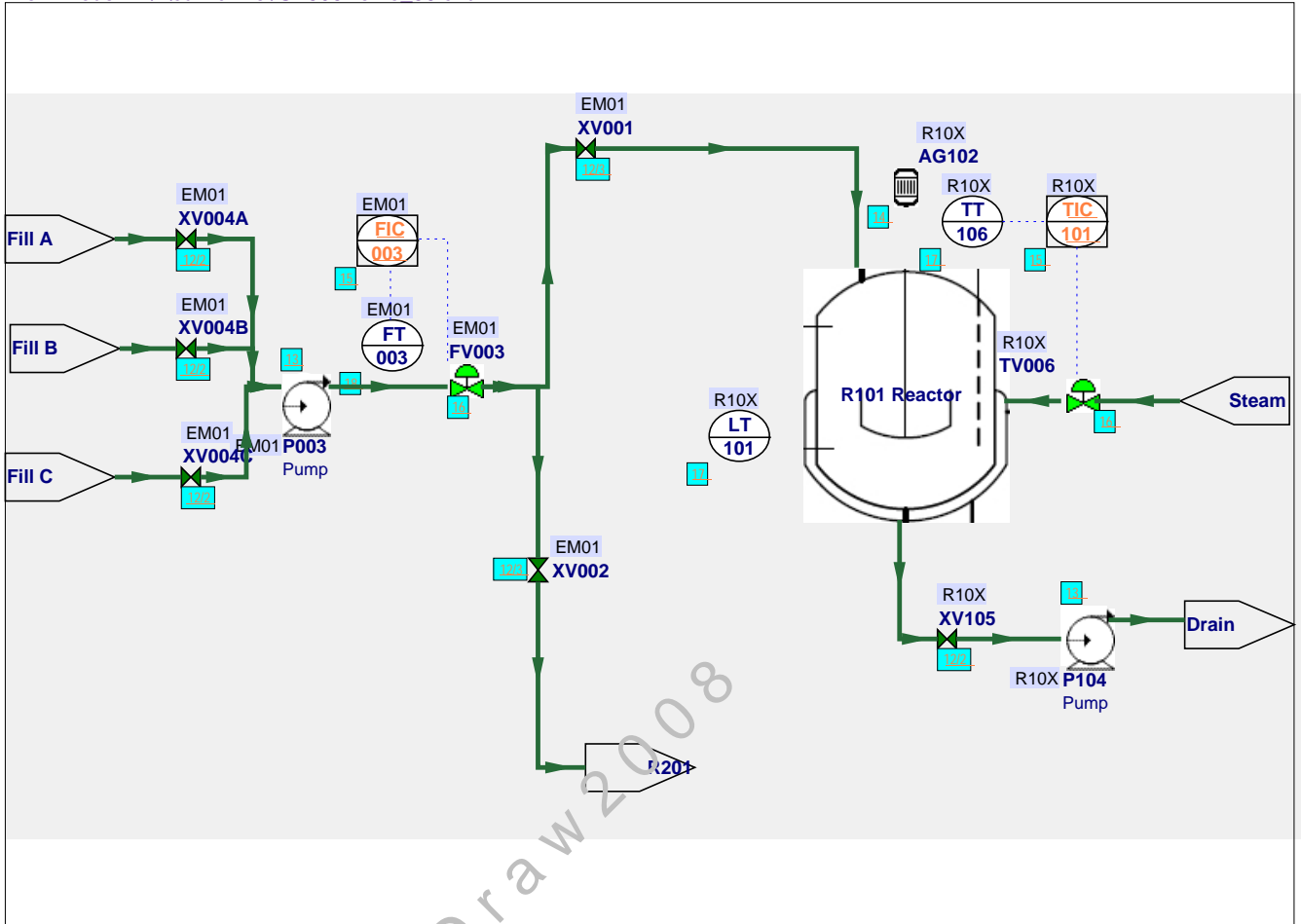


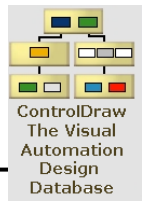
**Explanation**  
This shows the original P&ID with CM objects overlaid. In fact this was the starting point for the model, but the CMs were subsequently moved to their containing modules. It may be that the use will want to have a graphic like this.

Control Draw 2008



Previous diagram for Page 33, PageID 1  
Previous version, page 23, Version 24  
From model E:\FcdArchive\ISA506Demo\_56.cnd





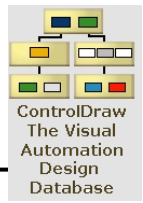
**Diagram 34 - R10x Interlock matrix**

Diagram Version: 91      Class: Logic Function

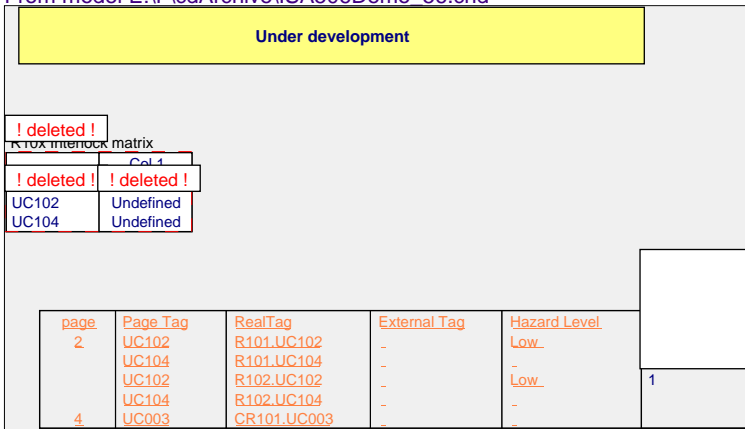
**Under development**

page	Page Tag	CM tag	Hazard Level	SIL Level
3	UC102	UC-102	Low	1
	UC104	UC-104		
	UC102	UC-102		
	UC104	UC-104		
5	UC003	UC-003		
16	UC10	UC-10		
	UC102	UC-102		
	UC104	UC-104		
	UC110	UC-110		

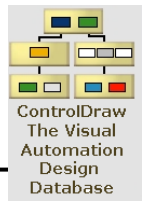
Control Draw 2008



Previous diagram for Page 34, PageID 27  
 Previous version, page 24, Version 34  
 From model E:\FcdArchive\ISA506Demo\_56.cnd

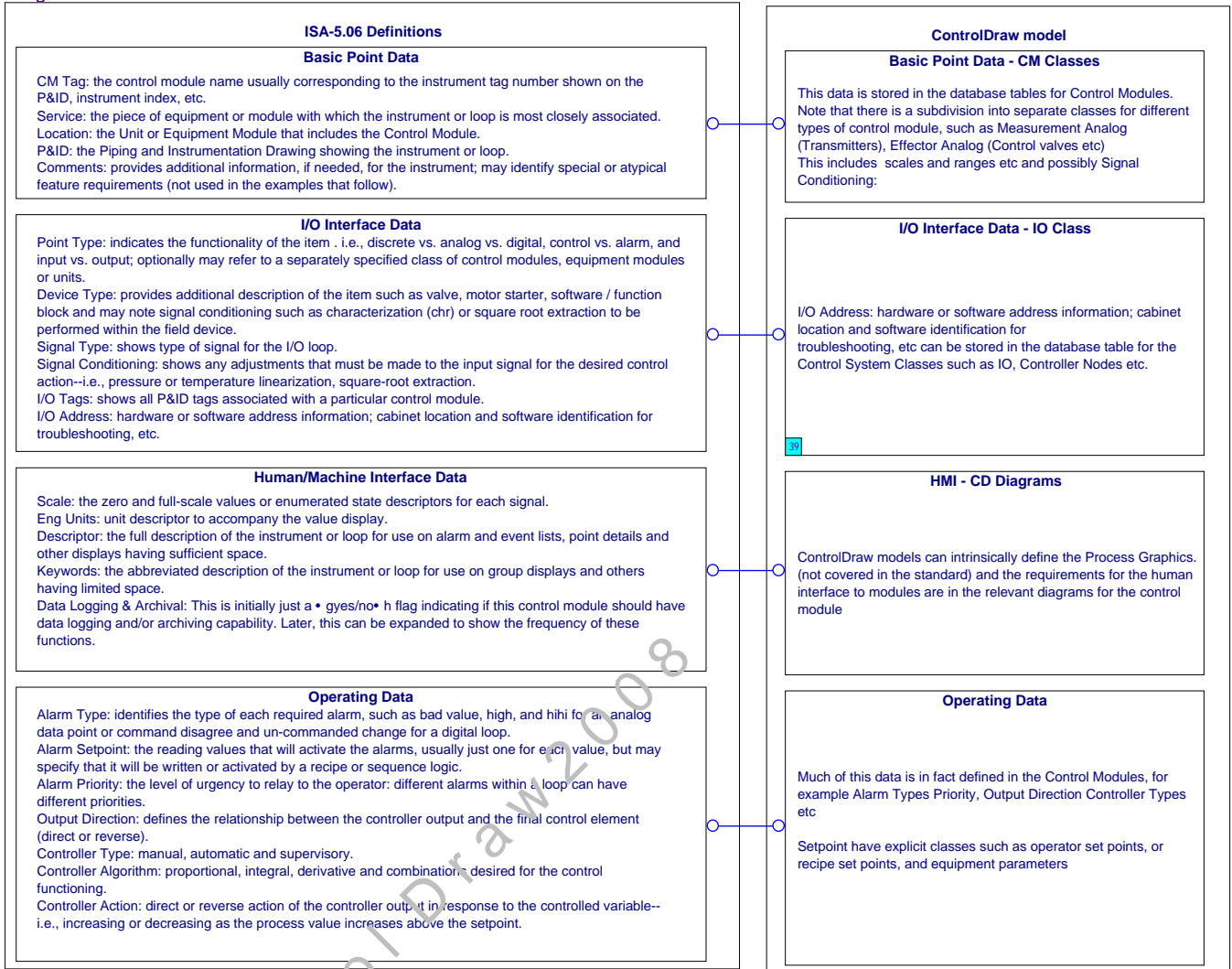


Control Draw 2008

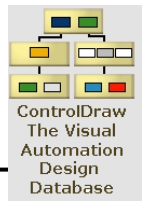


**Diagram 35 - Database**

Diagram Version: 42      Class: None



Previous version is same as current, 42



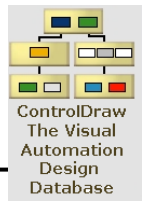
---

**Diagram 36 - Interlock Matrix**

Diagram Version: 24      Class: None

Previous version is same as current, 24

Control Draw 2008



**Diagram 37 - Sequence Matrix equivalences**

Diagram Version: 85 Class: None

THE Isa standard has 3 types of Sequence Matrix..  
 The ControlDraw model contains all the aspects covered by these but in a different, more object oriented way.  
 This diagram indicates how.

These are object on the unit and em diagrams

This data is provided by the Recipe and Phase Diagrams

Automatically generate by intrinsic version control

DEVICE TAGS	INITIAL	OPERATIONS					SHUT-DOWN PHASE	CHANGE CONTROL		
	PHASE	PHASE	PHASE	PHASE	PHASE	PHASE		DESCRIPTION	DATE	BY
		DISCRETE CONTROL MCDULES								
		ANALOG CONTROL MCDULES								
		START OF PHASE CONDITIONS								
		END OF PHASE CONDITIONS								
		ALLOWABLE PHASE TRANSITIONS								
		OPERATOR MESSAGES AND ACTIONS								
		BATCH REPORT VARIABLES								

**Figure 7a — Normal sequence matrix**

Hold sequence matrix

DEVICE TAGS	INITIAL	OPERATIONS					SHUT-DOWN PHASE	CHANGE CONTROL		
	PHASE	PHASE	PHASE	PHASE	PHASE	PHASE		DESCRIPTION	DATE	BY
		HOLD CONDITIONS								
		HOLD ACTIONS								
		OPERATOR MESSAGES								
		RECOVERY								

**Figure 7b — Hold sequence matrix**

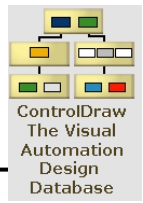
Recipe, equipment and operatro parameters are objects on the Recipe and Phase diagrams

Recipe Sequence Matrix

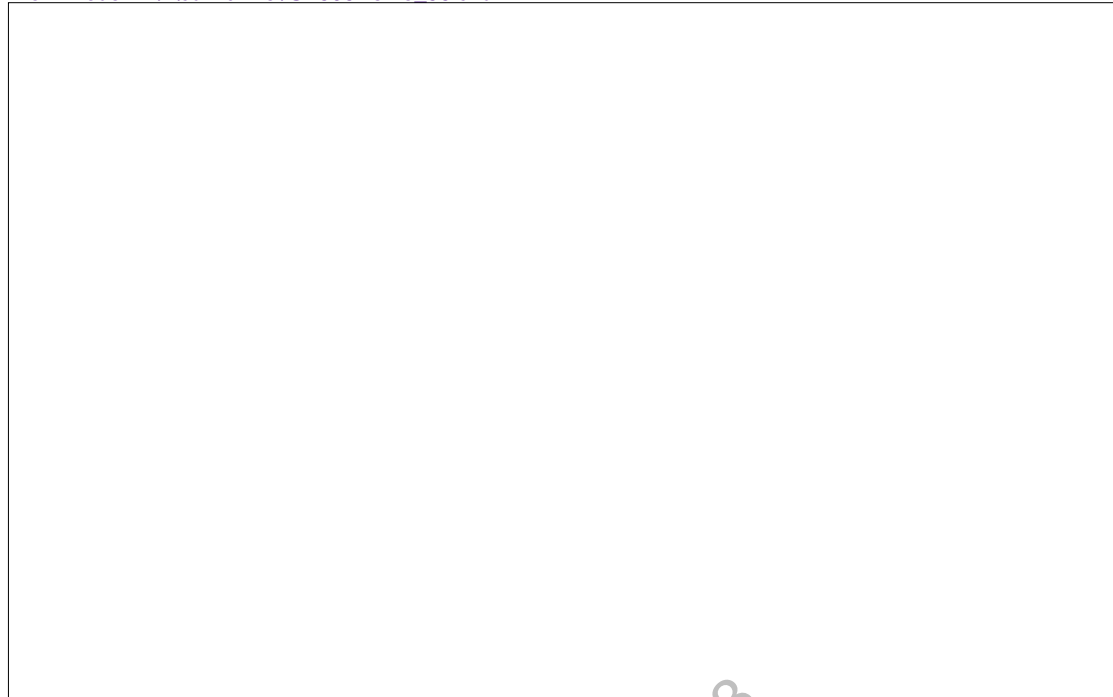
RECIPE PARAMETERS	INITIAL	OPERATIONS					SHUT-DOWN PHASE	CHANGE CONTROL		
	PHASE	PHASE	PHASE	PHASE	PHASE	PHASE		DESCRIPTION	DATE	BY
		VARIABLES CODED IN PROGRAM								
		VARIABLES ENTERED BY OPERATOR								
		VARIABLES ENTERED BY PRODUCTION SUPERVISOR								

**Figure 7c — Recipe sequence matrix**

Example 1 Sequence Matrices



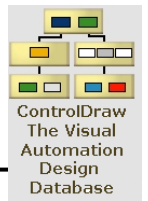
Previous diagram for Page 37, PageID 36  
Previous version, page 27, Version 47  
From model E:\FcdArchive\ISA506Demo\_56.cnd



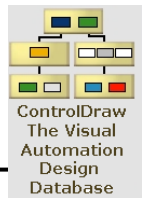
**! deleted !** Procedure Matrix is one method, but in this model PFC and SFC diagrams are used.  
This is an Example Procedure Matrix

Step	R10X
1	Initial
<b>! deleted !</b>	fill
3	Heat
4	Cure
5	Dump
6	Shutdown

Control Draw 2008

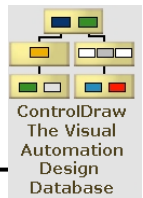


Control Draw 2008



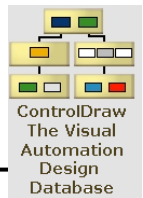
**Data Report: Control System IO - With changes**  
**(Compared with E:\fcdArchive\ISA506Demo\_56.cnd)**

RealTag	External Tag	PCSNode	IO Type	Card	Channel
R101.TT106.AI	TT-106.AI	Controller 1	AI	2	00
R101.TV006.AO	TV-006.AO	Controller 1	AO	5	00
R101.AG102.AO	AG-102.AO	Controller 1	AO	3	01
R101.AG102.DO	AG-102.DO	Controller 1	DO		
R101.AG102.DIClosed	AG-102.DIClosed	Controller 1	DI	1	14
R101.P104.DO	P-104.DO	Controller 1	DO		
R101.P104.DIRun	P-104.DIRun	Controller 1	DI	1	13
R101.XV105.DOXS	XV-105.DOXS	Controller 1	DO		
R101.XV105.DIZSC	XV-105.DIZSC	Controller 1	DI	1	06
R101.LT101.AI	LT-101.AI	Controller 1	AI	1	03
R101.LSHH203.DI		Controller 1	DI		
R102.TT106.AI	TT-106.AI	Controller 2	AI	1	02
R102.TV006.AO	TV-006.AO	Controller 2	AO	4	03
R102.AG102.AO	AG-102.AO	Controller 2	AO	3	00
R102.AG102.DO	AG-102.DO	Controller 2	DO		
R102.AG102.DIClosed	AG-102.DIClosed	Controller 2	DI	1	15
R102.P104.DO	P-104.DO	Controller 2	DO		
R102.P104.DIRun	P-104.DIRun	Controller 2	DI	1	12
R102.XV105.DOXS	XV-105.DOXS	Controller 2	DO		
R102.XV105.DIZSC	XV-105.DIZSC	Controller 2	DI	1	01
R102.LT101.AI	LT-101.AI	Controller 2	AI	1	01
R102.LSHH203.DI		Controller 2	DI		
C104.FT101.AI	FT-101.AI	Controller 3	AI	2	03
C104.FV101.AO	FV-101.AO	Controller 3	AO	4	02
C104.P102.DO	P-102.DO	Controller 3	DO		
C104.P102.DIRun	P-102.DIRun	Controller 3	DI	1	11
C104.LV004.AO	LV-004.AO	Controller 3	AO	4	01
C104.P111.DO	P-111.DO	Controller 3	DO		
C104.P111.DIRun	P-111.DIRun	Controller 3	DI	1	10
C104.TV104.AO	TV-104.AO	Controller 3	AO	4	00
C104.TT104.AI	TT-104.AI	Controller 3	AI	1	00
C104.FT107.AI	FT-107.AI	Controller 3	AI	2	02
C104.FV107.AO	FV-107.AO	Controller 3	AO	3	03
C104.LT107.AI	LT-107.AI	Controller 3	AI		
C104.P110.DO	P-110.DO	Controller 3 []	DO		
C104.P110.DIRun	P-110.DIRun	Controller 3 []	DI		
C104.LV107.AO	LV-107.AO	Controller 3	AO		
C104.LT104.AI	LT-104.AI	Controller 3	AI		
C104.TV107.AO	TV-107.AO	Controller 3	AO		
C104.TT107.AI	TT-107.AI	Controller 3	AI		
C104.LT101.AI	LT-101.AI	Controller 3	AI		
C104.PV11=06.AO	PV-11=06.AO	Controller 3	AO		
C104.FSL106.DI	FSL-106.DI	Controller 3 []	DI		
C104.PT106.AI	PT-106.AI	Controller 3	AI		
C104.TT106.AI	TT-106.AI	Controller 3	AI		
CR101.XV001.DOXS	XV-001.DOXS	Controller 1	DO		



RealTag	External Tag	PCSNode	IO Type	Card	Channel
CR101.XV001.DIZSC	XV-001.DIZSC	Controller 1	DI	1	00
CR101.XV001.DIZSO	XV-001.DIZSO	Controller 1	DI	1	07
CR101.FV003.AO	FV-003.AO	Controller 1	AO	3	02
CR101.FT003.AI	FT-003.AI	Controller 1	AI	2	01
CR101.P003.DO	P-003.DO	Controller 1	DO		
CR101.P003.DIRun	P-003.DIRun	Controller 1	DI	1	09
CR101.XV004A.DOXS	XV-004A.DOXS	Controller 1	DO		
CR101.XV004A.DIZSC	XV-004A.DIZSC	Controller 1	DI	1	02
CR101.XV004B.DOXS	XV-004B.DOXS	Controller 1	DO		
CR101.XV004B.DIZSC	XV-004B.DIZSC	Controller 1	DI	1	03
CR101.XV004C.DOXS	XV-004C.DOXS	Controller 1	DO		
CR101.XV004C.DIZSC	XV-004C.DIZSC	Controller 1	DI	1	04
CR101.XV002.DOXS	XV-002.DOXS	Controller 1	DO		
CR101.XV002.DIZSC	XV-002.DIZSC	Controller 1	DI	1	05
CR101.XV002.DIZSO	XV-002.DIZSO	Controller 1	DI	1	08

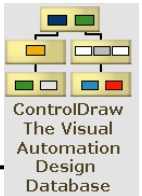
Control Draw 2008



**Data Report: Interlock Control Module - With changes**  
**(Compared with E:\fcdArchive\ISA506Demo\_56.cnd)**

ObjectTag	Page Tag	RealTag	DataVersion	External Tag	Hazard Level	SIL Level	Alarmed
UC	UC102	R101.UC102	12		Low	1	<input type="checkbox"/>
UC	UC104	R101.UC104	12				<input type="checkbox"/>
UC	UC102	R102.UC102	12		Low	1	<input type="checkbox"/>
UC	UC104	R102.UC104	12				<input type="checkbox"/>
UC	UC104	C104.UC104	42				<input type="checkbox"/>
UC	UC110	C104.UC110	42				<input type="checkbox"/>
UC	UC102	C104.UC102	51				<input type="checkbox"/>
UC	UC111	C104.UC111	51				<input type="checkbox"/>
UC	UC003	CR101.UC003	27				<input type="checkbox"/>

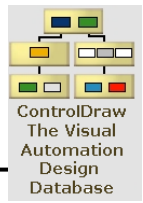
Control Draw 2008



Data Report: Measurement Analog - With changes  
 (Compared with E:\fcdArchive\ISA506Demo\_56.cnd)

RealTag	Scan rate Secs	IType	ScaleMin	ScaleMax	EngUnits	AlarmLLSP	AlarmLSP	AlarmHHSP	AlarmHSP	PCSNode	TrendGroup	TrendNo
R101.TT106	1	TT	0	100		0	0	99	95	Controller 1		
R101.LT101	1	LT	0	100		0	0	99	95	Controller 1		
R102.TT106	1	TT	0	100		0	0	99	95	Controller 2		
R102.LT101	1	LT	0	100		0	0	99	95	Controller 2		
C104.FT101	1	FT	0	100		0	0	99	95	Controller 3		
C104.TT104	1	TT	0	100		0	0	99	95	Controller 3		
C104.FT107	1	FT	0	100		0	0	99	95	Controller 3		
C104.LT107	1	LT	0	100		0	0	99	95	Controller 3		
C104.LT104	1	LT	0	100		0	0	99	95	Controller 3		
C104.TT107	1	TT	0	100		0	0	99	95	Controller 3		
C104.LT101	1	LT	0	100		0	0	99	95	Controller 3		
C104.PT106	1	PT	0	100		0	0	99	95	Controller 3		
C104.TT106	1	TT	0	100		0	0	99	95	Controller 3		
CR101.FT003	1	FT	0	100		0	0	99	95	Controller 1	CR101	

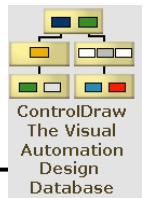
ControlDraw 2008



**Data Report: Measurement Switch - With changes**  
**(Compared with E:\fcdArchive\ISA506Demo\_56.cnd)**

RealTag	CM Tag	TimeOut	Switch Sense	PCSNode	TrendGroup	TrendNo
R101.LSHH203	LSHH-203	2	<input type="checkbox"/>	Controller 1		
R102.LSHH203	LSHH-203	2	<input type="checkbox"/>	Controller 2		
C104.FSL106	FSL-106	2	<input type="checkbox"/>	Controller 3		

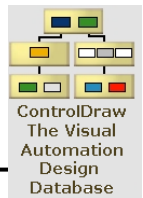
Control Draw 2008



**Data Report: Equipment Parameter - With changes**  
**(Compared with E:\fcdArchive\ISA506Demo\_56.cnd)**

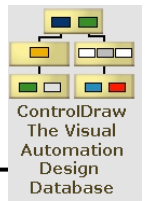
RealTag	DataVersion	PCSNode	Min	Value	Max	AllowChange
R101.epMinPumpLevel	94	Controller 1	0			<input type="checkbox"/>
R101.epMinAgitateLevel	94	Controller 1	0			<input type="checkbox"/>
R101.epEmptyLevel	94	Controller 1	0			<input type="checkbox"/>
R101.epDrainTime	94	Controller 1	0			<input type="checkbox"/>
R102.epMinPumpLevel	94	Controller 2	0			<input type="checkbox"/>
R102.epMinAgitateLevel	94	Controller 2	0			<input type="checkbox"/>
R102.epEmptyLevel	94	Controller 2	0			<input type="checkbox"/>
R102.epDrainTime	94	Controller 2	0			<input type="checkbox"/>

Control Draw 2008



**Data Report: Recipe Formula Value - With changes**  
**(Compared with E:\fcdArchive\ISA506Demo\_56.cnd)**

RealTag	External Tag	EU	Min	Value	Max	AllowChange	Scaleable
R101.ph Fill Material A.rpFillQtyA						<input type="checkbox"/>	<input type="checkbox"/>
R101.phHeat.fpCureTemperature						<input type="checkbox"/>	<input type="checkbox"/>
R101.ph Cure.rpCureTime						<input type="checkbox"/>	<input type="checkbox"/>
R101.ph Cure.fpCureTemperature						<input type="checkbox"/>	<input type="checkbox"/>
R101.ph Fill Material B.rpFillQtyB						<input type="checkbox"/>	<input type="checkbox"/>
R101.ph Fill Material C.rpFillQtyC						<input type="checkbox"/>	<input type="checkbox"/>
R102.ph Fill Material A.rpFillQtyA						<input type="checkbox"/>	<input type="checkbox"/>
R102.phHeat.fpCureTemperature						<input type="checkbox"/>	<input type="checkbox"/>
R102.ph Cure.rpCureTime						<input type="checkbox"/>	<input type="checkbox"/>
R102.ph Cure.fpCureTemperature						<input type="checkbox"/>	<input type="checkbox"/>
R102.ph Fill Material B.rpFillQtyB						<input type="checkbox"/>	<input type="checkbox"/>
R102.ph Fill Material C.rpFillQtyC						<input type="checkbox"/>	<input type="checkbox"/>
RP1.UP 1.ph Fill Material A.rpFillQtyA			750		775	<input type="checkbox"/>	<input type="checkbox"/>
RP1.UP 1.phHeat.fpCureTemperature						<input type="checkbox"/>	<input type="checkbox"/>
RP1.UP 1.ph Cure.rpCureTime			150		200	<input type="checkbox"/>	<input type="checkbox"/>
RP1.UP 1.ph						<input type="checkbox"/>	<input type="checkbox"/>
RP1.UP 1.fpCureTemperature		DegC				<input type="checkbox"/>	<input type="checkbox"/>
RP1.UP 1.rpFillQty		litre	750		775	<input type="checkbox"/>	<input type="checkbox"/>
RP1.UP 1.rpCureTime		Minutes	150		200	<input type="checkbox"/>	<input type="checkbox"/>
RP1.UP 1.ph Fill Material B.rpFillQtyB			750		775	<input type="checkbox"/>	<input type="checkbox"/>
RP1.UP 1.ph Fill Material C.rpFillQtyC			750		775	<input type="checkbox"/>	<input type="checkbox"/>
RP1.rp1CureTemperature		DegC		50		<input type="checkbox"/>	<input type="checkbox"/>
RP1.rp1FillQty		litre	750	750	775	<input type="checkbox"/>	<input type="checkbox"/>
RP1.rp1CureTime		Minutes	150	150	200	<input type="checkbox"/>	<input type="checkbox"/>
RP2.UP 1.ph Fill Material A.rpFillQtyA			850		875	<input type="checkbox"/>	<input type="checkbox"/>
RP2.UP 1.phHeat.fpCureTemperature			50		70	<input type="checkbox"/>	<input type="checkbox"/>
RP2.UP 1.ph Cure.rpCureTime			190		229	<input type="checkbox"/>	<input type="checkbox"/>
RP2.UP 1.ph			50		70	<input type="checkbox"/>	<input type="checkbox"/>
RP2.UP 1.fpCureTemperature		DegC	50		70	<input type="checkbox"/>	<input type="checkbox"/>
RP2.UP 1.rpFillQty		litre	850		875	<input type="checkbox"/>	<input type="checkbox"/>
RP2.UP 1.rpCureTime		Minutes	190		229	<input type="checkbox"/>	<input type="checkbox"/>
RP2.UP 1.ph Fill Material B.rpFillQtyB			850		875	<input type="checkbox"/>	<input type="checkbox"/>
RP2.UP 1.ph Fill Material C.rpFillQtyC			850		875	<input type="checkbox"/>	<input type="checkbox"/>
RP2.rp2CureTemperature		DegC	50	60	70	<input type="checkbox"/>	<input type="checkbox"/>
RP2.rp2FillQty		litre	850	850	875	<input type="checkbox"/>	<input type="checkbox"/>
RP2.rp2CureTime		Minutes	190	199	229	<input type="checkbox"/>	<input type="checkbox"/>
RP3.UP 1.ph Fill Material A.rpFillQtyA			950		975	<input type="checkbox"/>	<input type="checkbox"/>
RP3.UP 1.phHeat.fpCureTemperature			55		75	<input type="checkbox"/>	<input type="checkbox"/>
RP3.UP 1.ph Cure.rpCureTime			990		1000	<input type="checkbox"/>	<input type="checkbox"/>
RP3.UP 1.ph			55		75	<input type="checkbox"/>	<input type="checkbox"/>
RP3.UP 1.fpCureTemperature		DegC	55		75	<input type="checkbox"/>	<input type="checkbox"/>
RP3.UP 1.rpFillQty		litre	950		975	<input type="checkbox"/>	<input type="checkbox"/>
RP3.UP 1.rpCureTime		Minutes	990		1000	<input type="checkbox"/>	<input type="checkbox"/>
RP3.UP 1.ph Fill Material B.rpFillQtyB			950		975	<input type="checkbox"/>	<input type="checkbox"/>
RP3.UP 1.ph Fill Material C.rpFillQtyC			950		975	<input type="checkbox"/>	<input type="checkbox"/>
RP3.rp3CureTemperature		DegC	55	60	75	<input type="checkbox"/>	<input type="checkbox"/>
RP3.rp3FillQty		litre	950	950	975	<input type="checkbox"/>	<input type="checkbox"/>
RP3.rp3CureTime		Minutes	990	990	1000	<input type="checkbox"/>	<input type="checkbox"/>



*Pages deleted from E:\fcdArchive\ISA506Demo\_56.cnd*

Page	PageName	Class	ID	Version
------	----------	-------	----	---------

Control Draw 2008